

Technical Information

STG800 SmartLine Gauge Pressure Specification 34-ST-03-83, December 2024



Introduction

Part of the SmartLine® family of products, the STG800 and STG80L are high performance gauge pressure transmitter featuring piezoresistive sensor technology combining pressure sensing with on chip temperature compensation capabilities providing high accuracy, stability and performance over a wide range of application pressures and temperatures. The SmartLine family is also fully tested and compliant with Experion® PKS providing the highest level of compatibility assurance and integration capabilities. SmartLine easily meets the most demanding application needs for pressure measurement applications.

Best in Class Features:

- Accuracies up to 0.0375 % of span standard & 0.025% of span optional.
- Stability up to 0.015% of URL per year for 15 years.
- Automatic temperature compensation.
- Rangeability up to 100:1.
- Response times as fast as 80ms.
- Multiple local display capabilities.
- External zero, span, & configuration capability.
- Polarity insensitive electrical connections.
- Comprehensive on-board diagnostic capabilities.
- Integral Dual Seal design for highest safety based on ANSI/NFPA 70-202 and ANSI/ISA 12.27.1.
- Full compliance to SIL 2/3 requirements.
- Modular design characteristics.
- Available with an additional 15-year warranty.
- Plugged Impulse Line Detection Option.
- Supports NAMUR NE-107 Extended Diagnostics (FF).
- Dual/Triple Calibration Option (HART & Fieldbus Only).



Figure 1 – STG800 Gauge Pressure Transmitters feature field-proven piezoresistive sensor technology

Communications/Output Options:

- 4-20mA
- Honeywell Digitally Enhanced (DE)
- HART® (version 7.0)
- FOUNDATION™ Fieldbus

All transmitters are available with the above listed communications protocols.

Span & Range Limits:

Model	URL psi (bar)	LRL psi (bar)	Min Span psi (bar)
STG830/STG83L	50 (3.5)	-14.7 (-1.0)	0.5 (0.035)
STG840/STG84L	500 (35)	-14.7 (-1.0)	5 (0.35)
STG870/STG87L	3000 (210)	-14.7 (-1.0)	30 (2.1)
STG88L	6000 (420)	-14.7 (-1.0)	60 (4.2)
STG89L	10000 (690)	-14.7 (-1.0)	100 (6.9)

Description

The SmartLine family of gauge pressure, differential pressure, and absolute pressure transmitters is designed around a high performance piezo-resistive sensor. This one sensor actually integrates multiple sensors linking process pressure measurement with on-board static pressure (DP Models) and temperature compensation measurements resulting in the best total performance available. This level of performance allows the ST 800 to replace virtually any competitive transmitter available today.

Unique Indication/Display Options

The ST 800 modular design accommodates a standard alphanumeric LCD display or a unique advanced graphics LCD display with many unparalleled features.

Standard LCD Display Features

- Modular (may be added or removed in the field).
- Supports HART protocol variant.
- 0, 90, 180, & 270 degree position adjustments.
- Four configurable screens.
- Standard and custom measurement units available.
- Display calculated flow (square root) value in addition to analog output signal.
- 2 Lines 6 digits PV (9.95H x 4.20W mm) 8 Characters.
- Write protect Indication.
- Built-in Basic Device Configuration through Internal or External Buttons – Range/Engineering Unit/Loop Test /Loop Calibration/Zero /Span Setting.
- Multiple language capabilities (EN, RU).

Advanced Graphics LCD Display Features

- Modular (may be added or removed in the field).
- 0, 90, 180, & 270-degree position adjustments.
- Standard and custom measurement units available.
- Up to eight display screens with 3 formats are possible.
- Large PV with Bar Graph or PV with Trend Graph.
- Configurable screen rotation timing (1 to 30 sec).
- Display calculated flow (square root) value in addition to analog output signal.
- Unique “Health Watch” indication provides instant visibility of diagnostics.
- Multiple language capability (EN, DE, FR, IT, ES, RU, TR, CN, & JP).

Diagnostics

SmartLine transmitters all offer digitally accessible diagnostics which aid in providing advanced warning of possible failure events minimizing unplanned shutdowns, providing lower overall operational costs.

Configuration Tools

Integral Three Button Configuration Option

Suitable for all electrical and environmental requirements, SmartLine offer the ability to configure the transmitter and display via three externally accessible buttons when either display option is selected. Zero/span capabilities are also optionally available via these buttons with or without selection of a display option.

Handheld Configuration

SmartLine transmitters feature two-way communication and configuration capability between the operator and the transmitter. All Honeywell transmitters are designed and tested for compliance with the offered communication protocols and are designed to operate with any standards compliant handheld configuration device, such as the Honeywell Versatilis Configurator.

Personal Computer Configuration

On a personal computer or laptop, Honeywell Field Device Manager (FDM) Software and FDM Express can be used for managing HART & Fieldbus device configurations.

System Integration

- SmartLine communications protocols all meet the most current published standards for HART/DE/Fieldbus.
- Integration with Honeywell's Experion PKS offers the following unique advantages.
 - Transmitter messaging.
 - Maintenance mode indication.
 - Tamper reporting.
 - FDM Plant Area Views with Health summaries.
 - All ST 800 units are Experion tested to provide the highest level of compatibility assurance.

Modular Design

To help contain maintenance & inventory costs, all ST 800 transmitters are modular in design supporting the user's ability to replace meter bodies, add indicators or change electronic modules without affecting overall performance or approval body certifications. Each meter body is uniquely characterized to provide in-tolerance performance over a wide range of application variations in temperature and pressure and due to the Honeywell advanced interface, electronic modules may be swapped with any electronics module without losing in-tolerance performance characteristics.

Modular Features

- Meter body replacement
- Exchange/replace electronics/comms modules*
- Add or remove integral indicators*
- Add or remove lightning protection (terminal connection)*

* Field replaceable in all electrical environments (including IS) except flameproof without violating agency approvals.

With no performance effects, Honeywell's unique modularity results in **lower inventory needs and lower overall operating costs.**

Plugged Impulse Line Detection:

STG800 models are offered with a PILD option which provides indication of a plugged impulse line or process connection. When used in conjunction with an advanced display, a non-critical diagnostic indication appears on the integral display. For units without an integral display, an indication can be seen via the host or handheld device when HART Protocol is utilized.

Dual/Triple Calibration:

STG800 models are optionally offered with multiple calibrations. In lieu of a standard factory calibration, units can be supplied with 1, 2, or 3 customer specified calibrations. These calibrations are stored in the meter body and provide users with factory calibrated performance at up to three different calibrated ranges. This increases application flexibility without requiring any costly recalibration or additional inventory.

Performance Specifications

Reference Accuracy: (conformance to +/-3 Sigma)

Table 1

Model	URL	LRL	Min Span	Maximum Turndown Ratio	Stability (% URL/ Yr for 15 years)	Reference Accuracy ^{1,2} (% Span) Std / Opt.
STG830	50 psi (3.5 bar)	-14.7 psi (-1.0 bar)	0.5 psi (.035 bar)	100:1	0.010	0.0375 / 0.025
STG83L	50 psi (3.5 bar)	-14.7 psi (-1.0 bar)	0.5 psi (.035 bar)			
STG840	500 psi (35 bar)	-14.7 psi (-1.0 bar)	5 psi (.35 bar)			
STG84L	500 psi (35 bar)	-14.7 psi (-1.0 bar)	5 psi (.35 bar)			
STG870	3000 psi (210 bar)	-14.7 psi (-1.0 bar)	30 psi (2.1 bar)			
STG87L	3000 psi (210 bar)	-14.7 psi (-1.0 bar)	30 psi (2.1 bar)			
STG88L	6000 psi (420 bar)	-14.7 psi (-1.0 bar)	60 psi (4.2 bar)			
STG89L	10000 psi (690 bar)	-14.7 psi (-1.0 bar)	100 psi (6.9 bar)			0.055 / 0.04

Zero and span may be set anywhere within the listed (URL/LRL) range limits

Accuracy at Specified Span and Temperature: (Conformance to +/-3 Sigma)

Table 2

			Accuracy ^{1,2} (% of Span)				Combined Zero & Span Temperature Effect (% Span/28°C (50°F))	
	Model	URL	Reference Turndown	A	B	C (see URL units)	D	E
Standard Accuracy	STG830	50 psi (3.5 bar)	33.3:1	0.005	0.0325	1.5 (0.105)	0.030	0.003
	STG83L	50 psi (3.5 bar)	16.7:1			3 (0.21)		0.006
	STG840	500 psi (35 bar)	35:1			14.5 (1.0)	0.025	0.004
	STG84L	500 psi (35 bar)	35:1			14.5 (1.0)		0.007
	STG870	3000 psi (210 bar)	10:1			300 (21)		0.005
	STG87L	3000 psi (210 bar)	10:1			300 (21)		0.010
	STG88L	6000 psi (420 bar)	12:1			500 (35)		
	STG89L	10000 psi (690 bar)	10:1			1000 (69)		
High Accuracy Option	STG830	50 psi (3.5 bar)	33.3:1	0.005	0.0200	1.5 (0.105)	0.030	0.003
	STG83L	50 psi (3.5 bar)	16.7:1			3 (0.21)		0.006
	STG840	500 psi (35 bar)	35:1			14.5 (1.0)	0.025	0.004
	STG84L	500 psi (35 bar)	35:1			14.5 (1.0)		0.007
	STG870	3000 psi (210 bar)	10:1			300 (21)		0.005
	STG87L	3000 psi (210 bar)	10:1			300 (21)		0.010
	STG88L	6000 psi (420 bar)	12:1			500 (35)		
	STG89L	10000 psi (690 bar)	10:1			1000 (69)		
Turn Down Effect							Temp Effect	
$\pm [A + B] \quad \text{if Span} \geq C$ $\pm \left[A + B \left(\frac{C}{\text{Span}} \right) \right] \quad \text{if Span} < C$							$\pm [D + E \left(\frac{\text{URL}}{\text{Span}} \right)]$	

Total Performance (% of Span):

Total Performance Calculation: = +/- $\sqrt{(\text{Accuracy})^2 + (\text{Temperature Effect})^2}$

Total Performance Examples (for comparison): Standard accuracy 5:1 Turndown, +/-50°F (28°C) shift

STG830 @ 10 psi	0.059% of span	STG840 @ 100 psi	0.059% of span	STG870 @ 600 psi	0.063% of span
STG83L @ 10 psi	0.071% of span	STG84L @ 100 psi	0.071% of span	STG87L @ 600 psi	0.084% of span
STG88L @ 1200 psi	0.084% of span	STG89L @ 2000 psi	0.093% of span		

Typical Calibration Frequency:

Calibration verification is recommended every four (4) years

Notes:

1. Terminal Based Accuracy - Includes combined effects of linearity, hysteresis, and repeatability. Analog output adds 0.005% of span.
2. For zero based spans and reference conditions of: 25°C (77°F) for LRV>= 0 psia, 10 to 55% RH, and 316 Stainless Steel barrier diaphragm.

Operating Conditions – All Models

Parameter	Reference Condition		Rated Condition		Operative Limits		Transportation and Storage	
	°C	°F	°C	°F	°C	°F	°C	°F
Ambient Temperature ¹	25±1	77±2	-40 to 85	-40 to 185	-40 to 85	-40 to 185	-55 to 120	-67 to 248
Meter Body Temperature ²	25±1	77±2	-40 to 110 ¹	-40 to 230 ¹	-40 to 125	-40 to 257	-55 to 120	-67 to 248
Humidity %RH	10 to 55		0 to 100		0 to 100		0 to 100	
Vac. Region – Min. Pressure mmHg absolute inH ₂ O absolute	Atmospheric Atmospheric		25 13		2 (short term) ³ 1 (short term) ³			
Supply Voltage Load Resistance	HART: 10.8 to 42.4 VDC at terminals (IS versions limited to 30 VDC), 0 to 1,440 ohms DE: 15 to 49.3VDC at terminals (IS versions limited to 30VDC), 0 to 1,200 ohms (as shown in Figure 2) FOUNDATION Fieldbus: 9.0 to 32.0 VDC at terminals, steady state current: 17.6mA, software download current: 27.4mA							
Maximum Allowable Working Pressure (MAWP) ⁴ (Maximum allowable working pressure is the maximum pressure allowed for the normal transmitter operation. MAWP depends on Approval agencies and transmitter material of construction. MAWP are same as URL for gauge and absolute pressure transmitters)	STG830: 50 psi (3.5 bar)		STG83L: 50 psi (3.5 bar)		STG840: 500 psi (35 bar)		STG84L: 500 psi (35 bar)	
	STG840: 500 psi (35 bar)		STG84L: 500 psi (35 bar)		STG870: 3000 psi (210 bar)		STG87L: 3000 psi (210 bar)	
	STG870: 3000 psi (210 bar)		STG87L: 3000 psi (210 bar)		STG88L: 6000 psi (420 bar)		STG88L: 6000 psi (420 bar)	
					STG89L: 10000 psi (690 bar)		STG89L: 10000 psi (690 bar)	
Over pressure These are the pressure limits the transmitters can withstand without damage	STG830: 75 psi (5.25 bar) STG83L: 75 psi (5.25 bar) STG840: 1500 psi (103 bar) STG84L: 1500 psi (103 bar) STG870: 4500 psi (310 bar) STG87L: 4500 psi (310 bar) STG88L: 9000 psi (620 bar) STG89L: 15000 psi (1035 bar)							

¹ LCD Display operating temperature -20°C to +70°C . Storage temperature -30°C to 80°C.

² Silicone 704 minimum temperature rating is 0°C (32°F). CTFE minimum temperature rating is -40°C (-40°F).
NEOBEE M-20 minimum temperature rating is -15°C (5°F). NEOBEE® is a registered trademark of Stepan Company.

³ Short term equals 2 hours at 70°C (158°F).

⁴ Consult factory for MAWP of ST 800 transmitters with CRN approval.

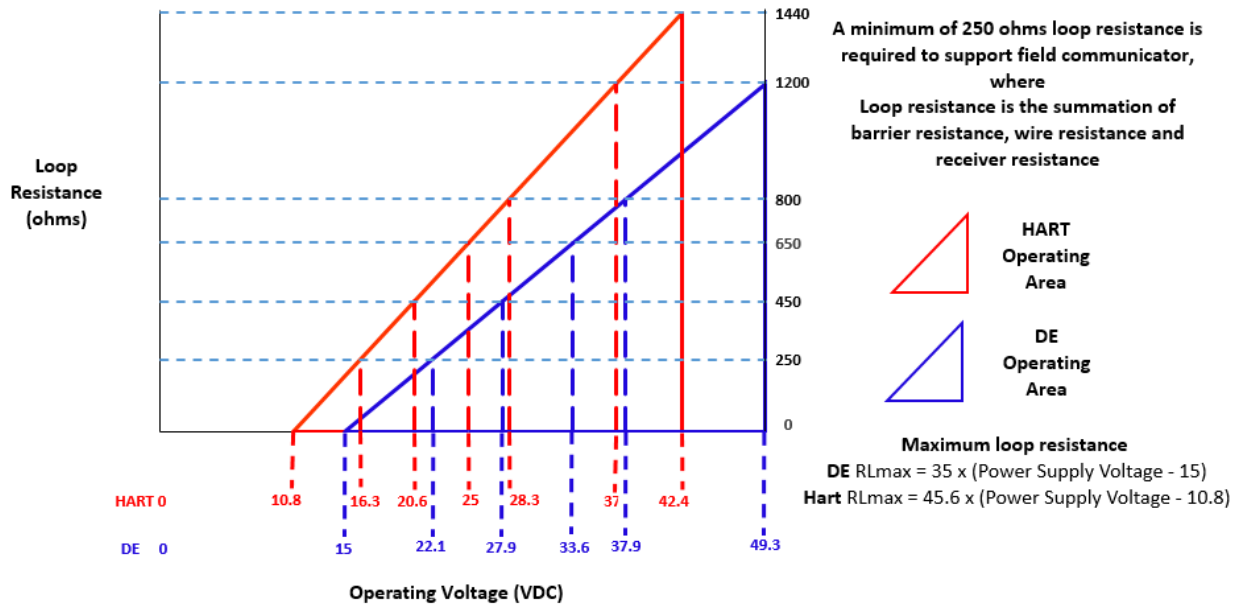

Figure 2 - Supply voltage and loop resistance chart & calculations

Performance Under Rated Conditions – All Models

Parameter	Description									
Analog Output Digital Communications:	Two-wire, 4 to 20 mA (HART & DE Transmitters only) Honeywell DE, HART protocol or FOUNDATION Fieldbus ITK 6.0.1 compliant All transmitters, irrespective of protocol have polarity insensitive connection									
HART & DE Output Failure Modes (NAMUR for DE Units requires selecting display and configuration buttons or factory configuration)	<table border="0"> <tr> <td></td> <td style="text-align: center;">Honeywell Standard</td> <td style="text-align: center;">NAMUR NE 43 Compliance</td> </tr> <tr> <td>Normal Limits:</td> <td style="text-align: center;">3.8 – 20.8 mA</td> <td style="text-align: center;">3.8 – 20.5 mA</td> </tr> <tr> <td>Failure Mode:</td> <td style="text-align: center;">≤ 3.6 mA and ≥ 21.0 mA</td> <td style="text-align: center;">≤ 3.6 mA and ≥ 21.0 mA</td> </tr> </table>		Honeywell Standard	NAMUR NE 43 Compliance	Normal Limits:	3.8 – 20.8 mA	3.8 – 20.5 mA	Failure Mode:	≤ 3.6 mA and ≥ 21.0 mA	≤ 3.6 mA and ≥ 21.0 mA
	Honeywell Standard	NAMUR NE 43 Compliance								
Normal Limits:	3.8 – 20.8 mA	3.8 – 20.5 mA								
Failure Mode:	≤ 3.6 mA and ≥ 21.0 mA	≤ 3.6 mA and ≥ 21.0 mA								
Supply Voltage Effect	0.005% span per volt									
Transmitter Turn on Time (includes power up & test algorithms)	HART or DE: 2.5 seconds Foundation Fieldbus: host dependent									
Response Time (delay + time constant)	<table border="0"> <tr> <td style="text-align: center;"><u>DE/HART Protocol</u></td> <td style="text-align: center;"><u>FOUNDATION Fieldbus</u></td> </tr> <tr> <td style="text-align: center;">80ms</td> <td style="text-align: center;">150ms (Host Dependent)</td> </tr> </table>	<u>DE/HART Protocol</u>	<u>FOUNDATION Fieldbus</u>	80ms	150ms (Host Dependent)					
<u>DE/HART Protocol</u>	<u>FOUNDATION Fieldbus</u>									
80ms	150ms (Host Dependent)									
Damping Time Constant	HART: Adjustable from 0 to 32 seconds in 0.1 increments. Default Value: 0.5 seconds DE: Discrete values 0, 0.16, 0.32, 0.48, 1, 2, 4, 8, 16, 32 seconds. Default Value: 0.48 seconds									
Vibration Effect	Less than +/- 0.1% of URL w/o damping Per IEC60770-1 field or pipeline, high vibration level (10-2000Hz: 0.21 displacement/3g max acceleration)									
Electromagnetic Compatibility	Complies with EMC directive 2004/108/EC per IEC 61326-3-1 (HART/ DE Units) IEC 61326-1 (FF Units)									
Lightning Protection Option	Leakage Current: 10uA max @ 42.4VDC 93C Impulse rating: <table border="0"> <tr> <td>8/20us</td> <td>5000A (>10 strikes)</td> <td>10000A (1 strike min.)</td> </tr> <tr> <td>10/1000us</td> <td>200A (> 300 strikes)</td> <td></td> </tr> </table>	8/20us	5000A (>10 strikes)	10000A (1 strike min.)	10/1000us	200A (> 300 strikes)				
8/20us	5000A (>10 strikes)	10000A (1 strike min.)								
10/1000us	200A (> 300 strikes)									

Materials Specifications (see model selection guide for availability/restrictions with various models)

Parameter	Description
Barrier Diaphragms Material	STG800: 316L SS, Hastelloy® C-276 ² , Monel® 400 ³ , Tantalum, Gold-plated 316L SS, Gold-plated Hastelloy® C-276, Gold-plated Monel® 400 STG80L: 316L SS, Hastelloy C-276
Process Head Material	STG800: Carbon Steel (Zinc Plated), 316 SS ⁴ , Hastelloy® C-276 ⁶ , Monel® 400 ⁷ STG80L: 316L SS, Hastelloy C-276 ⁶
Vent/Drain Valves & Plugs ¹	STG800: 316 SS ⁴ , Hastelloy C-276 ² , Monel 400 ⁷ STG80L: N/A
Head Gaskets	STG800: Glass-filled PTFE standard. Viton® and graphite are optional. STG80L: N/A
Meter Body Bolting	STG800: Carbon Steel (Zinc plated) standard. Options include 316 SS, NACE A286 SS bolts and nuts or NACE A286 SS bolts and 304 SS nuts STG80L: N/A
Mounting Bracket	Carbon Steel (Zinc-plated) or 304 SS or 316SS angle bracket or Carbon Steel or 304SS or 316SS flat bracket available with 2" pipe bracket. See Figure 3.
Fill Fluid	Silicone 200, CTFE, NEOBEE M-20 or Silicone 704
Electronic Housing	Pure Polyester Powder Coated Low Copper (<0.4%) – Aluminum. Meets Type 4X / IP66 / IP67. All stainless-steel housing is optional. Cover O ring material: Silicone.
Process Connections	STG800: ½ -inch NPT female, DIN 19213 (standard) STG80L: ½ -inch NPT female, ½ -inch NPT male, 9/16-18 high-pressure Cone and Thread female ⁸ , DIN19213 (except STG89L), G ½ -B Male threaded
Wiring	Accepts up to 16 AWG (1.5 mm diameter).
Dimensions	See Figure 4 and 5
Net Weight	STG800: 8.3 pounds (3.8 Kg). STG80L: 3.6 pounds (1.6 Kg) with Aluminum Housing

¹ Vent/Drains are sealed with Teflon®² Hastelloy® C-276 or UNS N10276.³ Monel® 400 or UNS N04400.⁴ Supplied as 316 SS or as Grade CF8M, the casting equivalent of 316 SS.⁵ Carbon Steel heads are zinc-plated and not recommended for water service due to hydrogen migration. For that service, use 316 stainless steel wetted Process Heads.⁶ Hastelloy® C-276 or UNS N10276. Supplied as indicated or as Grade CW12MW, the casting equivalent of Hastelloy® C-276.⁷ Monel® 400 or UNS N04400. Supplied as indicated or as Grade M30C, the casting equivalent of Monel® 400.⁸ 9/16 Aminco.

Communications Protocol & Diagnostics

HART Protocol

Version: HART 7

Foundation Fieldbus (FF)

Available Function Blocks

Block Type	Quantity	Execution Time
Resource	1	n/a
Transducer	1	n/a
Diagnostic	1	n/a
Analog Input	1*	30 ms
PID w/Autotune	1	45 ms
Integrator	1	30 ms
Signal Char (SC)	1	30 ms
LCD Display	1	n/a
Flow Block	1	30 ms
Input Selector	1	30 ms
Arithmetic	1	30 ms

* AI block may have two (2) additional instantiations.

All available function blocks adhere to FOUNDATION Fieldbus standards. PID blocks support ideal & robust PID algorithms with full implementation of Auto-tuning.

Link Active Scheduler

Transmitters can perform as a backup Link Active Scheduler and take over when the host is disconnected. Acting as a LAS, the device ensures scheduled data transfers typically used for the regular, cyclic transfer of control loop data between devices on the Fieldbus.

Number of Devices/Segment

Entity IS model: 6 devices/segment

Schedule Entries

18 maximum schedule entries

Number of VCR's: 24 max

Compliance Testing: Tested according to ITK 6.0.1

Software Download

Utilizes Class-3 of the Common Software Download procedure as per FF-883 which allows the field devices of any manufacturer to receive software upgrades from any host.

Honeywell Digitally Enhanced (DE)

DE is a Honeywell proprietary protocol which provides digital communications between Honeywell DE enabled field devices and Hosts.

Standard Diagnostics

ST 800 top level diagnostics are reported as either critical or non-critical and are readable via the DD/DTM/FDI tools or integral display. All critical diagnostics will appear on the Advanced and Standard integral displays, and some non-critical diagnostics will also appear on the Advanced integral display. Some of the diagnostics are listed below.

Critical Diagnostics

- Electronics Module Fault.
- Meter body Memory Corruption.
- Config Data Corruption.
- Electronics Module Diagnostics Failure.
- Meter body Critical Failure.
- Sensor Communication Timeout.

Non-Critical Diagnostics

- Electronics Module Fault.
- Display Failure.
- Electronics Module Comm Failure.
- Meter body Excess Correct.
- Sensor Over Temperature.
- Fixed Current Mode.
- PV Out of Range.
- No DAC Compensation.
- Tamper Attempt Alarm.

Refer to the product user manual for comprehensive list of diagnostics and details.









Other Certification Options

Materials

- NACE MRO175, MRO103, ISO15156

Hazardous Area Certifications

MSG CODE	AGENCY	TYPE OF PROTECTION	COMM. OPTION	ELECTRICAL PARAMETERS	AMBIENT TEMP (Ta)
A	FM Approvals™ USA	Explosionproof: Class I, Division 1, Groups A, B, C, D; Dust Ignition Proof: Class II, III, Division 1, Groups E, F, G; T6..T5 Class I, Zone 0/1, AEx db IIC T6..T5 Ga/Gb Class II, Zone 21, AEx tb IIIC T95° Db	All	Note 1	T5: -50 °C to 85°C T6: -50 °C to 65°C
		Intrinsically Safe: Class I, II, III, Division 1, Groups A, B, C, D, E, F, G: T4 Class I, Zone 0, AEx ia IIC T4 Ga FISCO Field Device (Only for FF Option) Ex ia IIC T4 Ga; Ex ic IIC T4 Gc	4-20 mA / DE/ HART	Note 2a	-50 °C to 70°C
			Foundation Fieldbus	Note 2b	-50 °C to 70°C
		Nonincendive: Class I, Division 2, Groups A, B, C, D locations, T4 Class I, Zone 2, AEx nA IIC T4 Gc	4-20 mA / DE/ HART/ Foundation Fieldbus	Note 1	-50 °C to 85°C
		Enclosure: Type 4X/ IP66/ IP67	All	All	-
		STANDARDS: FM Class 3600:2011; FM Class 3610: 2010; FM Class 3611: 2004; FM Class 3615: 2006; FM Class 3616: 2011; FM Class 3810: 2005; ANSI/ISA 60079-0: 2013; ANSI/UL 60079-1: 2015; ANSI/UL 60079-11: 2014; ANSI/ISA 60079-15: 2012; ANSI/UL 60079-26: 2017; ANSI/UL 60079-31: 2015; ANSI/NEMA 250: 2003; ANSI/ IEC 60529: 2004			
B	Canadian Standards Association (CSA) USA and Canada	Explosion Proof: Class I, Division 1, Groups A, B, C, D; Class II, Division 1, Groups E, F, G; Class III, Division 1, T6..T5 Class I Zone 1 AEx db IIC T6..T5 Ga/Gb Ex db IIC T6..T5 Ga/Gb Zone 22 AEx tb IIIC T95° Db Ex tb IIIC T95° Db	All	Note 1	T5: -50°C TO 85°C T6: -50°C TO 65°C
		Intrinsically Safe: Class I, II, III, Division 1, Groups A, B, C, D; Class II, Division 1, Groups E, F, G; Class III, Division 1, T4 Class I Zone 0, AEx ia IIC T4 Ga Class I Zone 2, AEx ic IIC T4 Gc Ex ia IIC T4 Ga Ex ic IIC T4 Gc FISCO Field Device (Only for FF Option) Ex ia IIC T4 Ga; Ex ic IIC T4 Gc	4-20 mA / DE/ HART	Note 2	-50°C TO 70°C
			Foundation Fieldbus	Note 2	-50°C TO 70°C
		Nonincendive: Class I, Division 2, Groups A, B, C, D; Class II, Division 2, Groups F, G; Class III, Division 2, T4 Class I Zone 2 AEx nA IIC T4 Gc Ex nA IIC T4 Gc	4-20 mA / DE/ HART/ Foundation Fieldbus	Note 1	-50°C to 85°C
		Enclosure: Type 4X/ IP66/ IP67	All	All	-

MSG CODE	AGENCY	TYPE OF PROTECTION	COMM. OPTION	ELECTRICAL PARAMETERS	AMBIENT TEMP (Ta)
		STANDARDS: CSA C22.2 No. 0-10; CSA C22.2 No. 94-M91; CSA C22.2 No. 25-1966; CSA C22.2 No. 30-M1986; CSA C22.2 No. 142-M1987; CSA C22.2 No. 157-92; CSA C22.2 No. 213-M1987; CSA-C22.2 No. 60529:05; CSA-C22.2 No. 60079-0:11; CSA-C22.2 No. 60079-1:11; CSA-C22.2 No. 60079-11:11; CSA-C22.2 No. 60079-15:12; CSA-C22.2 No. 60079-31:12; ISA 12.12.01-2010; ISA 60079-0: 2009; ISA 60079-11: 2011; ISA 60079-15: 2009; ISA 60079-26: 2008; ISA-60079-27:2007 (12.02.04)-2006 (R2011); UL 913 Ed. 6; UL 916:1998; ANSI/ISA-12.27.01-2011			
C	ATEX	Flameproof: SIRA 12ATEX2233X  II 1/2 G Ex db IIC T6..T5 Ga/Gb II 2 D Ex tb IIIC T95°C...T120°C Db	All	Note 1	T5: -50°C TO 85°C T6: -50°C TO 65°C
		Intrinsically Safe: SIRA 12ATEX2233X  II 1 G Ex ia IIC T4 Ga II 2 D Ex ia IIIC T125°C Db FISCO Field Device (Only for FF Option) II 1 G Ex ia IIC T4 Ga	4-20 mA / DE/ HART	Note 2	-50°C TO 70°C
		Zone 2, Increase Safety: SIRA 12ATEX4234X  II 3 G Ex ec IIC T4 Gc	4-20 mA / DE/ HART/	Note 1	-50°C TO 85°C
		Zone 2, Intrinsically Safe: SIRA 12ATEX4234X  II 3 G Ex ic IIC T4 Gc FISCO Field Device (Only for FF Option) II 3 G Ex ic IIC T4 Gc	4-20 mA / DE/ HART/ Foundation Fieldbus	Note 2	-50°C TO 85°C
		Enclosure: IP66/ IP67	All	All	-
		STANDARDS: EN 60079-0: 2018; EN 60079-1: 2014; EN 60079-7: 2015+A1:2018; EN 60079-11: 2012; EN 60079-26: 2015; EN 60079-31: 2014			
	UKEX	Flameproof: CSAE 22UKEX1021X  II 1/2 G Ex db IIC T6..T5 Ga/Gb II 2 D Ex tb IIIC T95°C...T120°C Db	All	Note 1	T5: -50°C TO 85°C T6: -50°C TO 65°C
		Intrinsically Safe: CSAE 22UKEX1021X  II 1 G Ex ia IIC T4 Ga II 2 D Ex ia IIIC T125°C Db FISCO Field Device (Only for FF Option) II 1 G Ex ia IIC T4 Ga	4-20 mA / DE/ HART	Note 2	-50°C TO 70°C
		Zone 2, Increase Safety: CSAE 22UKEX1008X  II 3 G Ex ec IIC T4 Gc	4-20 mA / DE/ HART/	Note 1	-50°C TO 85°C
		Zone 2, Intrinsically Safe: CSAE 22UKEX1008X  II 3 G Ex ic IIC T4 Gc FISCO Field Device (Only for FF Option) II 3 G Ex ic IIC T4 Gc	4-20 mA / DE/ HART/ Foundation Fieldbus	Note 2	-50°C TO 85°C

MSG CODE	AGENCY	TYPE OF PROTECTION	COMM. OPTION	ELECTRICAL PARAMETERS	AMBIENT TEMP (Ta)
		Enclosure: IP66/ IP67	All	All	-
		STANDARDS: EN 60079-0: 2018; EN 60079-1: 2014; EN 60079-7: 2015+A1:2018; EN 60079-11: 2012; EN 60079-26: 2015; EN 60079-31: 2014			
D	IECEX World	Flameproof: IECEx SIR 12.0100X Ex db IIC T6..T5 Ga/Gb Ex tb IIIC T95°C...T120°C Db	All	Note 1	T5: -50°C TO 85°C T6: -50°C TO 65°C
		Intrinsically Safe: IECEx SIR 12.0100X Ex ia IIC T4 Ga Ex ia IIIC T125°C Db FISCO Field Device (Only for FF Option) Ex ia IIC T4 Ga; Ex ic IIC T4 Gc	4-20 mA / DE/ HART	Note 2	-50°C TO 70°C
			Foundation Fieldbus	Note 2	-50°C TO 70°C
		Zone 2, Increase Safety: IECEx SIR 12.0100X Ex ec IIC T4 Gc	4-20 mA / DE/ HART/ Foundation Fieldbus	Note 1	-50°C TO 85°C
		Zone 2, Intrinsically Safe: IECEx SIR 12.0100X Ex ic IIC T4 Gc FISCO Field Device (Only for FF Option) Ex ic IIC T4 Gc	4-20 mA / DE/ HART/ Foundation Fieldbus	Note 2	-50°C TO 85°C
		Enclosure: IP66/ IP67	All	All	-
		STANDARDS: IEC 60079-0: 2017; IEC 60079-1: 2014; IEC 60079-7: 2017; IEC 60079-11: 2011; IEC 60079-26: 2014; IEC 60079-31: 2013			

E	SAEx South Africa	Flameproof : Ex d IIC T6...T5 Ga/Gb Ex tb IIIC T95°C...T120°C Db	All	Note 1	T5: -50°C TO 85°C T6: -50°C TO 65°C
		Intrinsically Safe: Ex ia IIC Ga T4 FISCO Field Device (Only for FF Option) Ex ia IIC T4 Ga; Ex ic IIC T4 Gc	4-20 mA / DE/ HART	Note 2	-50°C TO 70°C
			Foundation Fieldbus	Note 2	-50°C TO 70°C
		Zone 2, Increase Safety: II 3 G Ex ec IIC T4 Gc	4-20 mA / DE/ HART/ Foundation Fieldbus	Note 1	-50°C TO 85°C
		Zone 2, Intrinsically Safe: Ex ic IIC T4 Gc FISCO Field Device (Only for FF Option) Ex ic IIC T4 Gc	4-20 mA / DE/ HART/ Foundation Fieldbus	Note 2	-50°C TO 85°C
		Enclosure: IP66/ IP67	All	All	-
F	INMETRO Brazil	Flameproof: Ex db IIC T6..T5 Ga/Gb Ex tb IIIC T95°C...T120°C Db	All	Note 1	T5: -50°C TO 85°C T6: -50°C TO 65°C
		Intrinsically Safe: Ex ia IIC T4 Ga FISCO Field Device (Only for FF Option) Ex ia IIC T4 Ga; Ex ic IIC T4 Gc	4-20 mA / DE/ HART	Note 2a	-50°C TO 70°C
			Foundation Fieldbus	Note 2b	-50°C TO 70°C
		Zone 2, Increase Safety: II 3 G Ex ec IIC T4 Gc	4-20 mA / DE/ HART/ Foundation Fieldbus	Note 1	-50°C TO 85°C
		Zone 2, Intrinsically Safe: Ex ic IIC T4 Gc FISCO Field Device (Only for FF Option) Ex ic IIC T4 Gc	4-20 mA / DE/ HART/ Foundation Fieldbus	Note 2	-50°C TO 85°C
		Enclosure : IP 66/67	All	All	-
G	NEPSI CHINA	Flameproof: Ex db IIC T6..T5 Ga/Gb Ex tb IIIC T 95°C Db	All	Note 1	T5: -50°C TO 85°C T6: -50°C TO 65°C
		Intrinsically Safe: Ex ia IIC T4 Ga FISCO Field Device (Only for FF Option) Ex ia IIC T4 Ga; Ex ic IIC T4 Gc	4-20 mA / DE/ HART	Note 2	-50°C TO 70°C
			Foundation Fieldbus	Note 2	-50°C TO 70°C
		Zone 2, Increase Safety: II 3 G Ex ec IIC T4 Gc	4-20 mA / DE/ HART/ Foundation Fieldbus	Note 1	-50°C TO 85°C
		Zone 2, Intrinsically Safe: Ex ic IIC T4 Gc FISCO Field Device (Only for FF Option) Ex ic IIC T4 Gc	4-20 mA / DE/ HART/ Foundation Fieldbus	Note 2	-50°C TO 85°C
		Enclosure : IP 66/67	All	All	-

H	KOSHA Korea	Flameproof : Ex d IIC T4, T5, T6 Ex tD A21 IP66/IP67 T95°C...T120°C	All	Note 1	T4: -50°C TO 85°C T5: -50°C TO 85°C T6: -50°C TO 65°C
		Intrinsically Safe: Ex ia IIC T4	4-20 mA / DE/ HART	Note 2	Ta= -50 °C to 70°C
			Foundation Fieldbus	Note 2	Ta= -50 °C to 70°C
Enclosure: IP66/ IP67	All	All	-		
I	EAC Russia, Belarus and Kazakhstan	Flameproof: Ga/Gb Ex d IIC T6..T5 Ex tb IIIC Db T 85°C	All	Note 1	T5: -50°C TO 85°C T6: -50°C TO 65°C
		Intrinsically Safe: Ga Ex ia IIC T4 X FISCO Field Device (Only for FF Option) Ga Ex ia IIC T4 X	4-20 mA / DE/ HART	Note 2	-50°C TO 70°C
			Foundation Fieldbus	Note 2	-50°C TO 70°C
		Zone 2, Non Sparking: 2 Ex nA IIC T4 Gc X	4-20 mA / DE/ HART/ Foundation Fieldbus	Note 1	-50°C TO 85°C
		Zone 2, Intrinsically Safe: Ga Ex ic IIC T4 X FISCO Field Device (Only for FF Option) 2 Ex ic IIC T4 Gc X	4-20 mA / DE/ HART/ Foundation Fieldbus	Note 2	-50°C TO 85°C
Enclosure : IP 66/67	All	All			
J	CCoE INDIA	Flameproof: Ex d IIC T6..T5 Ga/Gb	All	Note 1	T5: -50°C TO 85°C T6: -50°C TO 65°C
		Intrinsically Safe: Ex ia IIC T4 Ga FISCO Field Device (Only for FF Option) Ex ia IIC T4 Ga; Ex ic IIC T4 Gc	4-20 mA / DE/ HART	Note 2	-50°C TO 70°C
			Foundation Fieldbus	Note 2	-50°C TO 70°C
		Non Sparking Ex nA IIC T4 Gc	4-20 mA / DE/ HART/ Foundation Fieldbus	Note 1	-50°C TO 85°C
Enclosure: IP66/ IP67	All	All	-		
K	UATR UKRAINE	Flameproof: II 1/2 G Ex db IIC T6..T5 Ga/Gb II 2 D Ex tb IIIC T95°C...T120°C Db	All	Note 1	T5: -50°C TO 85°C T6: -50°C TO 65°C
		Intrinsically Safe: II 1 G Ex ia IIC T4 Ga FISCO Field Device (Only for FF Option) II 1 G Ex ia IIC T4 Ga	4-20 mA / DE/ HART	Note 2	-50°C TO 70°C
			Foundation Fieldbus	Note 2	-50°C TO 70°C
Enclosure: IP66/ IP67	All	All	-		

Notes:

1. Operating Parameters:

Voltage = 11 to 42 VDC Current = 4-20 mA Normal
 = 9 to 32 V (FF) = 30 mA (FF)

2. Intrinsically Safe Entity Parameters

a. Analog/DE/HART Entity Values:

Vmax = Ui = 30V I_{max} = I_i = 105mA Ci = 4.2nF Li = 984 uH Pi = 0.9W

Transmitter with Terminal Block revision E or Later

Vmax = Ui = 30V I_{max} = I_i = 225mA Ci = 4.2nF Li = 0 Pi = 0.9W

Note : Transmitter with Terminal Block revision E or later

The revision is on the label that is on the module. There will be two lines of text on the label:

- First is the Module Part #: 50049839-001 or 50049839-002
- Second line has the supplier information, along with the REVISION:

XXXXXX-EXXX, THE "X" is production related, THE POSITION of the "E" IS THE REVISION

b. Foundation Fieldbus Entity Values

Vmax = Ui = 30V I_{max} = I_i = 180mA Ci = 0nF Li = 984 uH Pi = 1W

Transmitter with Terminal Block revision F or Later

Vmax = Ui = 30V I_{max} = I_i = 225mA Ci = 0nF Li = 0 Pi = 1 W

FISCO Field Device

Vmax = Ui = 17.5V I_{max} = I_i = 380 mA Ci = 0nF Li = 0 Pi = 5.32 W

Note : Transmitter with Terminal Block revision F or later

The revision is on the label that is on the module. There will be two lines of text on the label:

- First is the Module Part #: 50049839-003 or 50049839-004
- Second line has the supplier information, along with the REVISION:

XXXXXX-EXXX, THE "X" is production related, THE POSITION of the "E" IS THE REVISION

Approval Certifications

Marine Certificates	This certificate defines the certifications covered for the ST 800 Pressure Transmitter family of products, including the SMV 800 Smart Multivariable Transmitter. It represents the compilation of the five certificates Honeywell currently has covering the certification of these products into marine applications. For ST 800 Smart Pressure Transmitter and SMV800 Smart Multivariable Transmitter																
	American Bureau of Shipping (ABS) - 2009 Steel Vessel Rules 1-1-4/3.7, 4-6-2/5.15, 4-8-3/13 & 13.5, 4-8-4/27.5.1, 4-9-7/13. Certificate number: 04-HS417416-PDA																
	Bureau Veritas (BV) - Product Code: 389:1H. Certificate number: 12660/B0 BV																
	Det Norske Veritas (DNV) - Location Classes: Temperature D, Humidity B, Vibration A, EMC B, Enclosure C. For salt spray exposure; enclosure of 316 SST or 2-part epoxy protection with 316 SST bolts to be applied. Certificate number: A-11476																
	Korean Register of Shipping (KR) - Certificate number: LOX17743-AE001																
	Lloyd's Register (LR) - Certificate number: 02/60001(E1) & (E2)																
SIL 2/3 Certification	IEC 61508 SIL 2 for non-redundant use and SIL 3 for redundant use according to EXIDA and TÜV Nord Sys Tec GmbH & Co. KG under the following standards: IEC61508-1: 2010; IEC 61508-2: 2010; IEC61508-3: 2010.																
MEASUREMENT INSTRUMENTS DIRECTIVE (MID) 2004/ 22/ EC	<p>Certificate Issued by NMI Certin B.V. Mechanical Class: M3 Electromagnetic Environment: E3 Ambient Temperature Range: -25 °C to + 55 °C</p> <table border="1"> <thead> <tr> <th>Unit</th> <th>Custom Calibration</th> </tr> </thead> <tbody> <tr> <td>STD820</td> <td>0 to 1000 mBar</td> </tr> <tr> <td>STD830</td> <td>0 to 7 Bar</td> </tr> <tr> <td>STA84L</td> <td>0 to 35 Bar A</td> </tr> <tr> <td>STG84L</td> <td>0 to 35 Bar</td> </tr> <tr> <td>STD870</td> <td>0 to 100 Bar</td> </tr> <tr> <td>STA87L</td> <td>0 to 100 Bar A</td> </tr> <tr> <td>STG87L</td> <td>0 to 100 Bar</td> </tr> </tbody> </table>	Unit	Custom Calibration	STD820	0 to 1000 mBar	STD830	0 to 7 Bar	STA84L	0 to 35 Bar A	STG84L	0 to 35 Bar	STD870	0 to 100 Bar	STA87L	0 to 100 Bar A	STG87L	0 to 100 Bar
Unit	Custom Calibration																
STD820	0 to 1000 mBar																
STD830	0 to 7 Bar																
STA84L	0 to 35 Bar A																
STG84L	0 to 35 Bar																
STD870	0 to 100 Bar																
STA87L	0 to 100 Bar A																
STG87L	0 to 100 Bar																

Mounting & Dimensional Drawings

Mounting Configurations: (Dual head design)

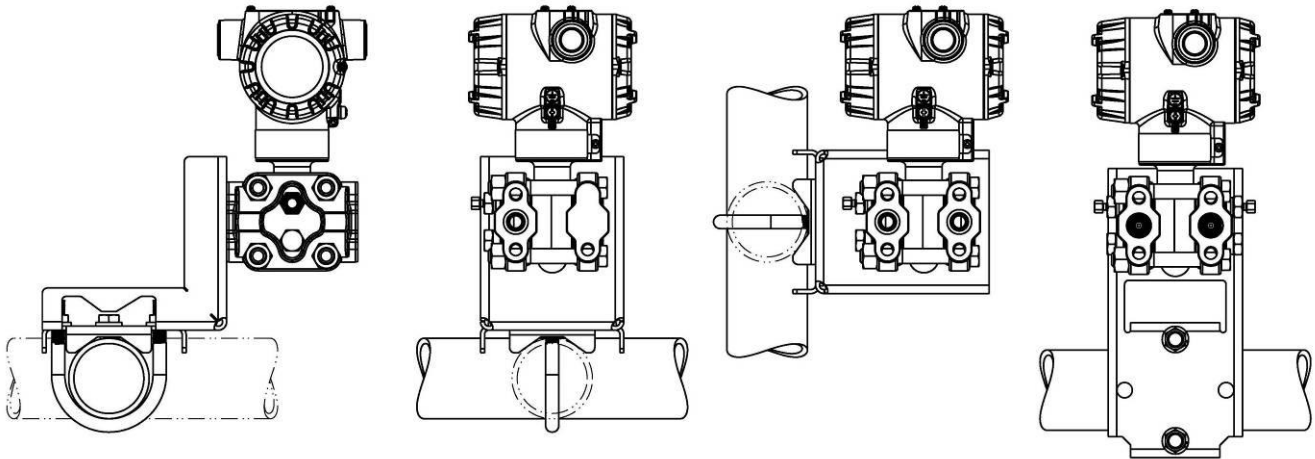

Mounting Configurations (Inline Designs)

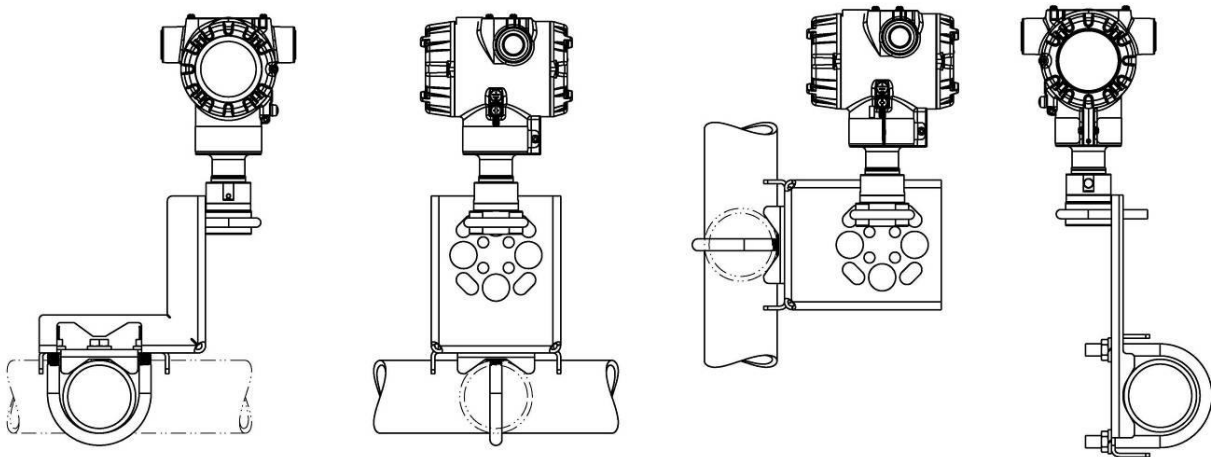

Figure 3 – Typical mounting configuration of dual head and inline designs for reference

Reference Dimensions: $\frac{\text{millimeters}}{\text{inches}}$

Dimensions: (Dual head design)

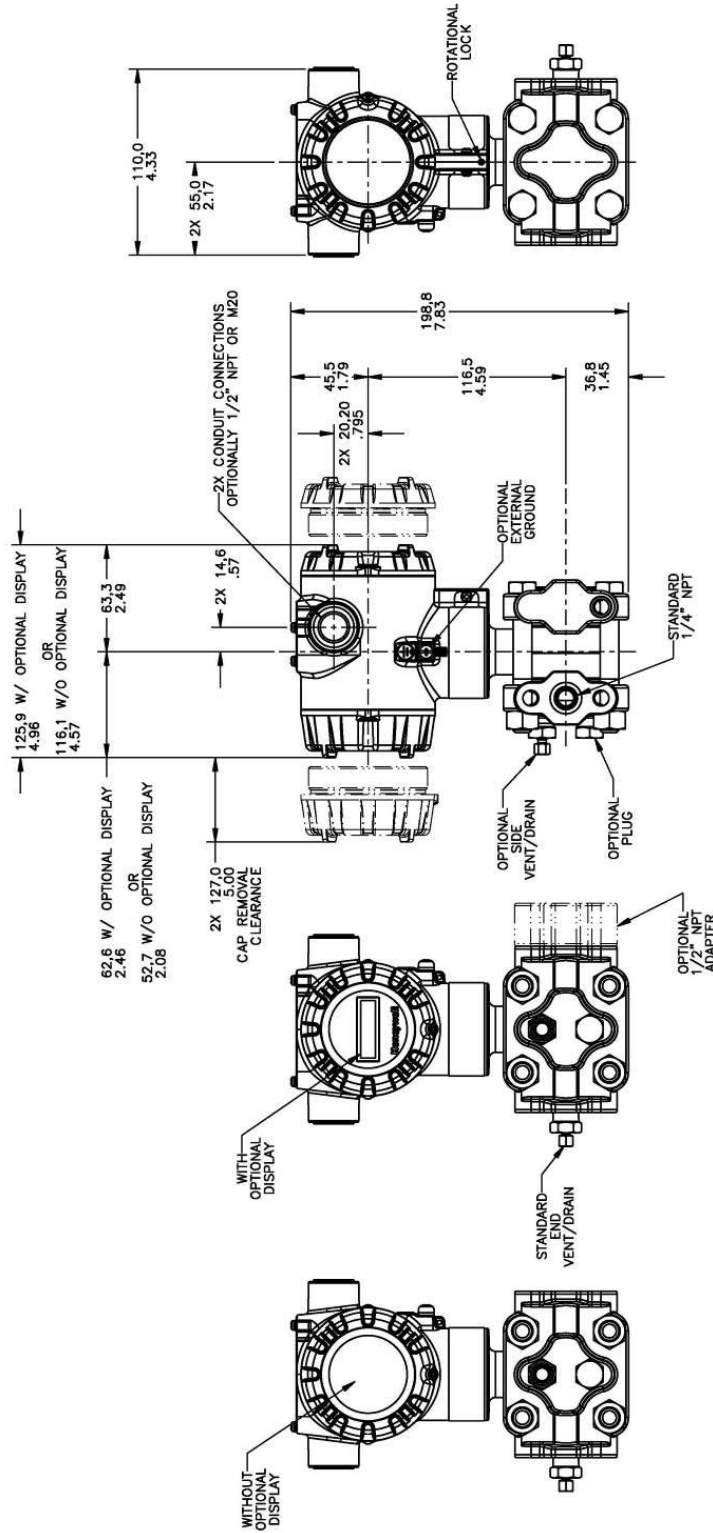

Figure 4 – Typical mounting dimensions of STG840 & STG870 for reference

Reference Dimensions: $\frac{\text{millimeters}}{\text{inches}}$

Dimension (Inline Design)

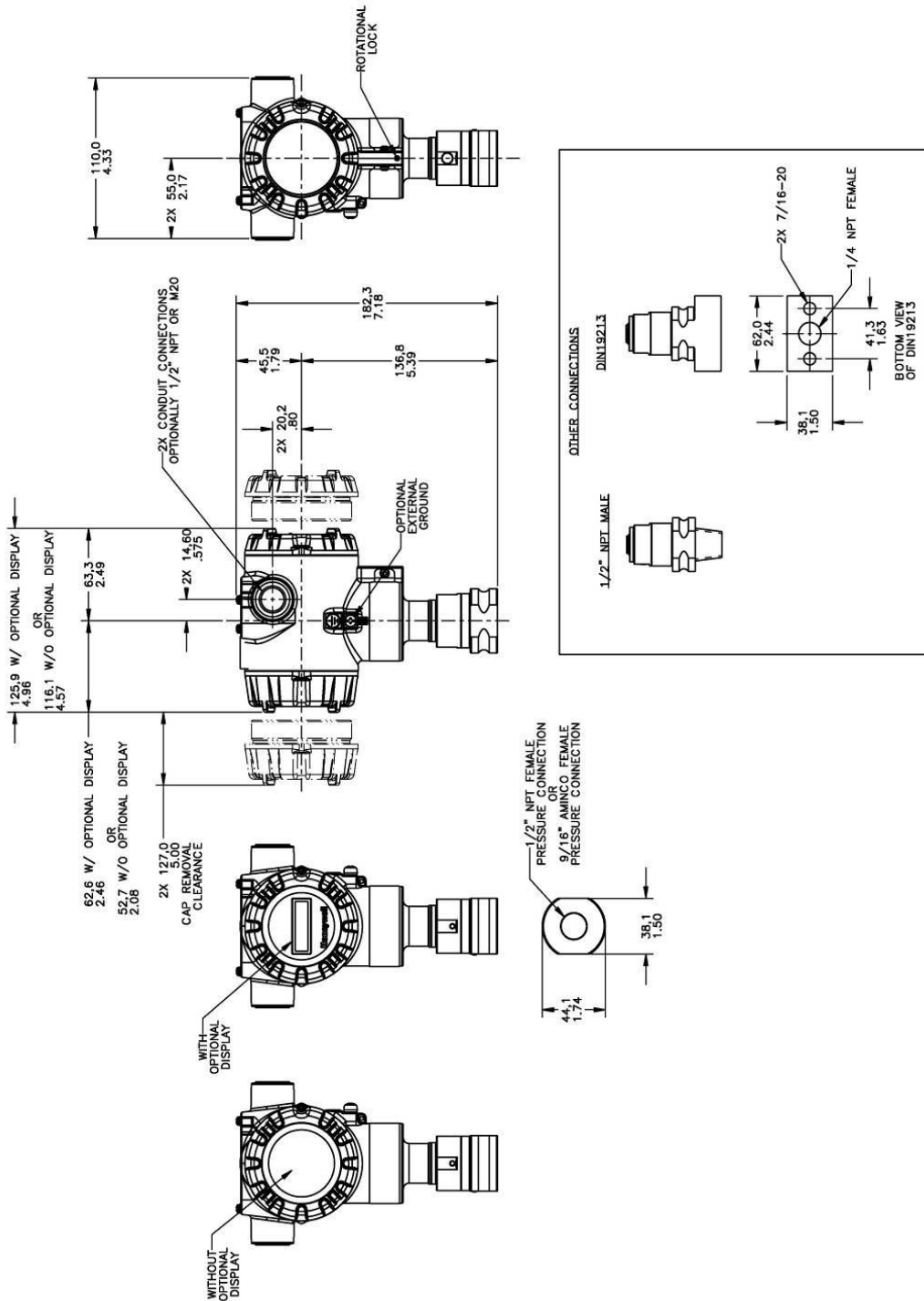

Figure 5 – Typical mounting dimensions of STG84L, STG87L, STG88L, & STG89L for reference

Model Selection Guide

Model Selection Guides are subject to change and are inserted into the specifications as guidance only.

Model STG800 Gauge Pressure Transmitters

Model Selection Guide
34-ST-16-83 Issue 31

Instructions: Make selections from all Tables using column below the proper arrow. Asterisk indicates availability. Letter (a) refers to restrictions highlighted in the restrictions table. Tables delimited with dashes.
List Price: Price equals the sum of prices for all selections made.
 Key: [STG] - [I] - [II] - [III] - [IV] - [V] - [VI] - [VII] - [VIII (Optional)] - [IX] [0000]

KEY NUMBER	URL/Max Span	LRL	Min Span	Units
Gauge Dual Head	50 (3.5)	-14.7 (-1.0)	0.5 (.035)	psi (bar)
	500 (35)	-14.7 (-1.0)	5 (.35)	psi (bar)
	3000 (210)	-14.7 (-1.0)	30 (2.1)	psi (bar)
Gauge In-Line	50 (3.5)	-14.7 (-1.0)	0.5 (.035)	psi (bar)
	500 (35)	-14.7 (-1.0)	5 (.35)	psi (bar)
	3000 (210)	-14.7 (-1.0)	30(2.1)	psi (bar)
	6000 (420)	-14.7 (-1.0)	60 (4.2)	psi (bar)
	10000 (690)	-14.7 (-1.0)	100 (6.9)	psi (bar)

Selection	Availability				
STG830	↓				
STG840	↓				
STG870	↓				
STG83L		↓			
STG84L			↓		
STG87L				↓	
STG88L					↓
STG89L					↓

TABLE I	METER BODY SELECTIONS			
a. Process Head & Diaphragm Materials	Process Head/Reference Head Material ^{1b}		Barrier Diaphragm Material	
	Plated Carbon Steel / Carbon Steel	Plated	316L SS	Hastelloy [®] C - 276
			Monel 400 [®]	Tantalum
	316 Stainless Steel /316 Stainless Steel ^{1c}		Gold Plated 316L SS	Gold Plated Hastelloy C-276
Gold Plated Monel 400				
316L SS			Hastelloy C - 276	
Hastelloy C - 276 / 316 Stainless Steel		Monel 400	Tantalum	
		Gold Plated 316L SS	Gold Plated Hastelloy C-276	
Monel 400 / 316 Stainless Steel		Gold Plated Monel 400	Hastelloy C - 276	
			Tantalum	
b. Fill Fluid	Silicone Oil 200		Hastelloy C-276	
	Fluorinated Oil CTFE		Tantalum	
	Silicone Oil 704		Gold Plated Hastelloy C-276	
	NEOBEE [®] M-20		Gold Plated Monel 400	
c. Process Connection	Size/Type		Material	
	9/16" Aminco		Same as Process Head	
	1/2" NPT (female)		Same as Process Head ^{1a}	
	1/2" NPT (male)		Same as Process Head	
	DIN 19213 (1/4" female NPT)		Same as Process Head	
	G 1/2 B Threaded Fitting		Same as Process Head	
d. Bolt/Nuts Materials	M20		Same as Process Head	
	None			
	Carbon Steel			
	316 SS			
	Grade 660 (NACE A286) with NACE 304 SS Nuts			
	Grade 660 (NACE A286) Bolts & Nuts			
	Monel K500			
Super Duplex				
B7M				
e. Vent/Drain Type/Location	Head Type	Vent Type	Location	Vent Material
	None	None	None	None
	Single Ended	None	None	None
	Single Ended	Standard Vent	Side	Matches Head Material ¹
	Single Ended	Center Vent	Side	Stainless Steel Only
	Dual Ended	Standard Vent	End	Matches Head Material ¹
	Dual Ended	Center Vent	End	Stainless Steel only
Dual Ended	Std Vent/Plug	Side/End	Matches Head Material ¹	
f. Gasket Materials	None			
	Teflon [®] or PTFE (Glass Filled)			
	Viton [®]			
	Graphite			

A	*	*					
B	*	*					
C	*	*					
D	a	a					
1	*	*					
2	*	*					
3	*	*					
E	*	*	*	*	*	*	*
F	*	*	*	*	*	*	*
G	*	*					
H	a	a					
4	*	*					
5	*	*					
6	*	*					
J	*	a	*	*	*	*	*
K	a	a					
7	*	*					
L	a	a					
8	a	a					
_1	*	*	*	*	*	*	*
_2	*	*	*	*	*	*	*
_3	*	*	*	*	*	*	*
_4	*	*	*	*	*	*	*

_A	*	*	*	*	*	*	*
_G	*	*	*	*	*	*	*
_H	*	*	*	*	*	*	*
_D	*	*	*	*	*	*	*
_B	*	*	*	*	*	*	*
_N	*	*	*	*	*	*	*
_0	*	*	*	*	*	*	*
_C	*	*	*	*	*	*	*
_S	*	*	*	*	*	*	*
_N	*	*	*	*	*	*	*
_K	p	p	*	*	*	*	*
_M	p	p	*	*	*	*	*
_D	p	p	*	*	*	*	*
_B	*	*	*	*	*	*	*

_0	*	*	*	*	*	*	*
_1	*	*	*	*	*	*	*
_2	*	*	*	*	*	*	*
_3	t	t	*	*	*	*	*
_4	*	*	*	*	*	*	*
_5	t	t	*	*	*	*	*
_6	*	*	*	*	*	*	*
0	*	*	*	*	*	*	*
A	*	*	*	*	*	*	*
B	*	*	*	*	*	*	*
C	*	*	*	*	*	*	*

¹ Except Carbon Steel Heads shall use 316SS Vent/Drain & Plugs and or 1/2" adapters
^{1a} STG830,840,870 supplied via 1/2" flange adapter same material as process head except carbon steel shall use 316 SS
^{1b} Reference head available with Dual Head Gage models only. In-Line Gage models are supplied with Process Head only.
^{1c} When selected for In-Line Gage models the Process Head / Bonnet is supplied in Dual Certified SS316/316L

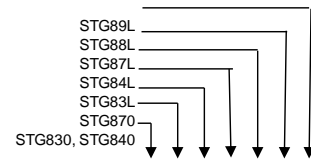

TABLE II METER BODY & CONNECTION ORIENTATION		
Head/Connect Orientation	Standard	High Side Left, Low Side Right ² / Std Head Orientation
	Reversed	Low Side Left, High Side Right ² / Std Head Orientation
	90/Standard	High Side Left, Low Side Right ² / 90° Head Rotation

1	*	*	*	*	*	*
2	*	*				
3	h	h				

TABLE III AGENCY APPROVALS	
Approvals	No Approvals Required
	<FM> Explosion proof, Intrinsically Safe, Non-incendive, & Dustproof
	CSA Explosion proof, Intrinsically Safe, Non-incendive, & Dustproof
	ATEX Explosion proof, Intrinsically Safe & Non-incendive
	IECEx Explosion proof, Intrinsically Safe & Non-incendive
	SAEx Explosion proof, Intrinsically Safe & Non-incendive
	INMETRO Explosion proof, Intrinsically Safe & Non-incendive
	NEPSI Explosion proof, Intrinsically Safe & Non-incendive
	KOSHA Explosion proof, Intrinsically Safe & Non-incendive
	EAC Customs Union(Russia,Belarus,Kazakhstan)Ex Approval, Flame proof, Intrinsically Safe
	CCoE Explosion proof, Intrinsically Safe & Non-incendive
	UATR Flameproof, Intrinsically Safe & Dustproof

0	*	*	*	*	*	*
A	*	*	*	*	*	*
B	*	*	*	*	*	p
C	*	*	*	*	*	*
D	*	*	*	*	*	*
E	*	*	*	*	*	*
F	*	*	*	*	*	*
G	*	*	*	*	*	*
H	*	*	*	*	*	*
I	*	*	*	*	*	*
J	*	*	*	*	*	*
K	*	*	*	*	*	*

TABLE IV TRANSMITTER ELECTRONICS SELECTIONS			
a. Electronic Housing Material & Connection Type	Material	Connection	Lightning Protection
	Polyester Powder Coated Aluminum	1/2 NPT	None
	Polyester Powder Coated Aluminum	M20	None
	Polyester Powder Coated Aluminum	1/2 NPT	Yes
	Polyester Powder Coated Aluminum	M20	Yes
	316 Stainless Steel (Grade CF8M)	1/2 NPT	None
	316 Stainless Steel (Grade CF8M)	M20	None
	316 Stainless Steel (Grade CF8M)	1/2 NPT	Yes
b. Output/ Protocol	Analog Output		Digital Protocol
	4-20mA dc		HART Protocol
	4-20mA dc		DE Protocol
c. Customer Interface Selections	Indicator	Ext Zero, Span & Config Buttons	Languages
	None	None	None
	None	Yes (Zero/Span Only)	None
	Advanced	None	EN, GR, FR, IT, SP, RU, TU
	Advanced	Yes	EN, GR, FR, IT, SP, RU, TU
	Advanced	None	EN, CH, JP
	Advanced	Yes	EN, CH, JP
	Standard (w/internal Zero, Span & Conf Buttons)	None	EN, RU
Standard (w/internal Zero, Span & Conf Buttons)	Yes	EN, RU	
Foundation Fieldbus	Foundation Fieldbus		

A__	*	*	*	*	*	*
B__	*	*	*	*	*	*
C__	*	*	*	*	*	*
D__	*	*	*	*	*	*
E__	*	*	*	*	*	*
F__	*	*	*	*	*	*
G__	*	*	*	*	*	*
H__	*	*	*	*	*	*

H	*	*	*	*	*	*
D	u	u	u	u	u	u
F	*	*	*	*	*	*

__0	*	*	*	*	*	*
__A	f	f	f	f	f	f
__D	*	*	*	*	*	*
__E	*	*	*	*	*	*
__H	*	*	*	*	*	*
__J	*	*	*	*	*	*
__S	q	q	q	q	q	q
__T	q	q	q	q	q	q

TABLE V CONFIGURATION SELECTIONS			
a. Application Software	Diagnostics		
	Standard Diagnostics		
b. Output Limit, Failsafe & Write Protect Settings	Advanced Diagnostics (Above with Plugged Impulse Detection PILD)		
	Write Protect	Fail Mode	High & Low Output Limits ³
	Disabled	High> 21.0mAdc	Honeywell Std (3.8 - 20.8 mAdc)
	Disabled	Low< 3.6mAdc	Honeywell Std (3.8 - 20.8 mAdc)
	Enabled	High> 21.0mAdc	Honeywell Std (3.8 - 20.8 mAdc)
	Enabled	Low< 3.6mAdc	Honeywell Std (3.8 - 20.8 mAdc)
	Enabled	N/A	N/A Fieldbus or Profibus
Disabled	N/A	N/A Fieldbus or Profibus	
c. General Configuration	General Configuration		
	Factory Standard		
Custom Configuration (Unit Data Required from customer)			

1__	*	*	*	*	*	*
2__	*	*	*	*	*	*

1	f	f	f	f	f	f
2	f	f	f	f	f	f
3	f	f	f	f	f	f
4	f	f	f	f	f	f
5	g	g	g	g	g	g
6	g	g	g	g	g	g

__S	*	*	*	*	*	*
__C	*	*	*	*	*	*

² Left side/Right side as viewed from the customer connection perspective

³ NAMUR Output Limits are configurable by customer

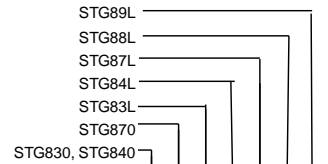

TABLE VI CALIBRATION & ACCURACY SELECTIONS			
	Accuracy	Calibrated Range	Calibration Qty
Accuracy and Calibration	Standard	Factory Standard	Single Calibration
	Standard	Custom (Unit Data Required)	Single Calibration
	Standard	Custom (Unit Data Required)	Dual Calibration
	Standard	Custom (Unit Data Required)	Triple Calibration
	High Accuracy	Factory Standard	Single Calibration
	High Accuracy	Custom (Unit Data Required)	Single Calibration
	High Accuracy	Custom (Unit Data Required)	Dual Calibration
	High Accuracy	Custom (Unit Data Required)	Triple Calibration

A	*	*	*	*	*	*	*
B	*	*	*	*	*	*	*
C	*	*	*	*	*	*	*
D	*	*	*	*	*	*	*
E	s	s	s	s	s	s	s
F	s	s	s	s	s	s	s
G	s	s	s	s	s	s	s
H	s	s	s	s	s	s	s

TABLE VII ACCESSORY SELECTIONS		
	Bracket Type	Material
a. Mounting Bracket	None	None
	Angle Bracket	Carbon Steel
	Angle Bracket	304 SS
	Angle Bracket	316 SS
	Marine Approved Bracket	Carbon Steel
	Marine Approved Bracket (In-Line)	Carbon Steel
	Marine Approved Bracket	304 SS
	Marine Approved Bracket (In-Line)	304 SS
	Flat Bracket	Carbon Steel
	Flat Bracket	304 SS
Flat Bracket	316 SS	
b. Customer Tag	Customer Tag Type	
	No customer tag	
	One Wired Stainless Steel Tag (Up to 4 lines 26 char/line)	
c. Unassembled Conduit Plugs & Adapters	Unassembled Conduit Plugs & Adapters	
	No Conduit Plugs or Adapters Required	
	1/2 NPT Male to 3/4 NPT Female 316 SS Certified Conduit Adapter	
	1/2 NPT 316 SS Certified Conduit Plug	
	M20 316 SS Certified Conduit Plug	
Minifast® 4 pin (1/2 NPT) (not suitable for X-Proof applications)		
Minifast® 4 pin (M20) (not suitable for X-Proof applications)		

0 ___	*	*	*	*	*	*	*
1 ___	*	*	*	*	*	*	*
2 ___	*	*	*	*	*	*	*
3 ___	*	*	*	*	*	*	*
8 ___	*	*	*	*	*	*	*
9 ___	*	*	*	*	*	*	*
4 ___	*	*	*	*	*	*	*
A ___	*	*	*	*	*	*	*
5 ___	*	*	*	*	*	*	*
6 ___	*	*	*	*	*	*	*
7 ___	*	*	*	*	*	*	*

_ 0 _ _	*	*	*	*	*	*	*
_ 1 _ _	*	*	*	*	*	*	*
_ 2 _ _	*	*	*	*	*	*	*

_ _ A0	*	*	*	*	*	*	*
_ _ A2	n	n	n	n	n	n	n
_ _ A6	n	n	n	n	n	n	n
_ _ A7	m	m	m	m	m	m	m
_ _ A8	n	n	n	n	n	n	n
_ _ A9	m	m	m	m	m	m	m

TABLE VIII OTHER Certifications & Options: (String in sequence comma delimited (XX, XX, XX,...))	
Certifications & Warranty	No additional options
	Low Temperature Rating (-50 deg C min. ambient operative temperature limit)
	NACE MR0175; MR0103; ISO15156 (FC33338) Process wetted parts only
	NACE MR0175; MR0103; ISO15156 (FC33339) Process wetted and non-wetted parts
	Marine (DNV, ABS, BV, KR, LR)
	EN10204 Type 3.1 Material Traceability (FC33341)
	MID Approved Transmitter - Contact Tech Support for specific MID approved ranges
	Certificate of Conformance (F3391)
	Calibration Test Report & Certificate of Conformance (F3399)
	Certificate of Origin (F0195)
	FMEDA (SIL 2/3) Certification (FC33337)
	Over-Pressure Leak Test Certificate (1.5X MAWP) (F3392)
	Cert Clean for O ₂ or CL ₂ service per ASTM G93
	PMI Certification
	Extended Warranty Additional 1 year
	Extended Warranty Additional 2 years
Extended Warranty Additional 3 years	
Extended Warranty Additional 4 years	
Extended Warranty Additional 15 years	

00	*	*	*	*	*	*	*
LT	w	w	w	w	w	w	w
FG	*	*	*	*	*	*	*
F7	c	c	c	c	c	c	c
MT	d	d	d	d	d	d	d
FX	*	*	*	*	*	*	*
MD	*	*	*	v	v	*	*
F3	*	*	*	*	*	*	*
F1	*	*	*	*	*	*	*
F5	*	*	*	*	*	*	*
FE	j	j	j	j	j	j	j
TP	*	*	*	*	*	*	*
OX	e	e	e	e	e	e	e
PM	*	*	*	*	*	*	*
01	*	*	*	*	*	*	*
02	*	*	*	*	*	*	*
03	*	*	*	*	*	*	*
04	*	*	*	*	*	*	*
15	*	*	*	*	*	*	*

TABLE IX Manufacturing Specials	
Factory	Factory Identification

0 0 0 0	*	*	*	*	*	*	*
---------	---	---	---	---	---	---	---

RESTRICTIONS

Restriction Letter	Available Only with		Not Available with	
	Table	Selection(s)	Table	Selection(s)
a			VIII	FG, F7
b		Select Only one option from this group		
c	Id	0,N,K,D,B	I a	D,H,K,L,8
d	IV a	C,D,G,H	VIIa	1,2,3,5,6,7
e	Ib	2		
f			IV b	F
g			IVb	H, D
h			Ie	4, 5, 6
			VIIa	1,2,3,4,5,6,7,8
j	IV b	H	Vb	1,2,6
m	IV a	B,D, F, H		
n	IV a	A,C, E, G		
p			III	B- No CRN number available
q	IV b	H		
s	Ia	A,E		
t			Ia	J, K, 7, L, 8
			Va	2
u			VIIa	C,D,G,H
v	IV a	C,D,G,H	IVb	D,F
w	Ib	1	VIII	FE

¹The PM option is available on all Smartline Pressure Transmitter process wetted parts such as process heads, flanges, bushings and vent plugs except plated carbon steel process heads and flanges. PM option information is also available on diaphragms except Gold plated and STG and STA in-line construction pressure transmitters.

FIELD INSTALLABLE ACCESSORY KITS

Description
Integrally Mounted Basic Indicator Kit (Compatible with all Electronic Modules)
Integrally Mounted Advanced Indicator Kit (compatible with all Electronic Modules)
Terminal Strip w/o Lightning Protection for HART or DE Modules
Terminal Strip w/Lightning Protection Kit for HART or DE Modules
Terminal Strip w/o Lightning Protection FFB/ <i>Profibus</i> Module
Terminal Strip w/Lightning Protection Kit for FFB/ <i>Profibus</i> Module
HART Electronics Module
HART Electronics Module w/connection for external configuration buttons
DE Electronics Module
DE Electronics Module w/connection for external configuration buttons
FFB Electronics Module Kit
FFB Electronics Module w/connection for external configuration buttons

Kit Number
50049911-501
50049846-501
50075472-531
50075472-532
50075472-533
50075472-534
50049849-501
50049849-502
50049849-503
50049849-504
50049849-507
50049849-508

Price
Note P
Note P
Note P
Note P
Note P
Note P
Note P
Note P
Note P
Note P
Note P
Note P

Note P - For part number pricing please refer to WEB Channel

PRODUCT MANUALS

Description
ST 800 SmartLine Transmitter User Manual - English
ST 800 SmartLine Transmitter HART/DE Communications Manual - English
ST 800 SmartLine Transmitter Safety Manual - English
ST 800 SmartLine Transmitter Foundation Fieldbus Manual - English
ST 800 SmartLine Transmitter Function Block Manual - English

Part Number
34-ST-25-35
34-ST-25-38
34-ST-25-37
34-ST-25-39
34-ST-25-42

All product documentation is available at www.process.honeywell.com.

Sales and Service

For application assistance, current specifications, ordering, pricing, and name of the nearest Authorized Distributor, contact one of the offices below.

ASIA PACIFIC

Honeywell Process Solutions,
Phone: + 800 12026455 or
+44 (0) 1202645583
(TAC) hfs-tac-support@honeywell.com

Australia

Honeywell Limited
Phone: +(61) 7-3846 1255
FAX: +(61) 7-3840 6481
Toll Free 1300-36-39-36
Toll Free Fax:
1300-36-04-70

China – PRC - Shanghai

Honeywell China Inc.
Phone: (86-21) 5257-4568
Fax: (86-21) 6237-2826

Singapore

Honeywell Pte Ltd.
Phone: +(65) 6580 3278
Fax: +(65) 6445-3033

South Korea

Honeywell Korea Co Ltd
Phone: +(822) 799 6114
Fax: +(822) 792 9015

EMEA

Honeywell Process Solutions,
Phone: + 800 12026455 or
+44 (0) 1202645583

Email: (Sales)

FP-Sales-Apps@Honeywell.com

or

(TAC)

hfs-tac-support@honeywell.com

Web

Knowledge Base search
engine <http://bit.ly/2N5Vldi>

AMERICAS

Honeywell Process Solutions,
Phone: (TAC) (800) 423-9883
or (215) 641-3610
(Sales) 1-800-343-0228

Email: (Sales)

FP-Sales-Apps@Honeywell.com

or

(TAC)

hfs-tac-support@honeywell.com

Web

Knowledge Base search
engine <http://bit.ly/2N5Vldi>

Specifications are subject to change without notice.

For more information

To learn more about SmartLine Transmitters,
visit www.process.honeywell.com
Or contact your Honeywell Account Manager

Process Solutions

Honeywell
1250 W Sam Houston Pkwy S
Houston, TX 77042

Honeywell Control Systems Ltd
Honeywell House, Skimped Hill Lane
Bracknell, England, RG12 1EB

Shanghai City Centre, 100 Jungi Road
Shanghai, China 20061

www.process.honeywell.com



34-ST-03-83
December 2024

©2024 Honeywell International Inc.