

Honeywell

**krom
schroder**



valvario[®]

VAD, VAG, VAV, VAH, ...



Pressure regulators with solenoid valve VAD, VAG, VAV, VAH

Flow rate regulator VRH

Pressure regulators with double solenoid valve VCD, VCG, VCV, VCH

- All-purpose servo regulator for gaseous media with integrated safety valve
- Suitable for a max. inlet pressure of 500 mbar (7 psig)
- Minimum installation effort: no external impulse line required
- Setting options from two sides

Application

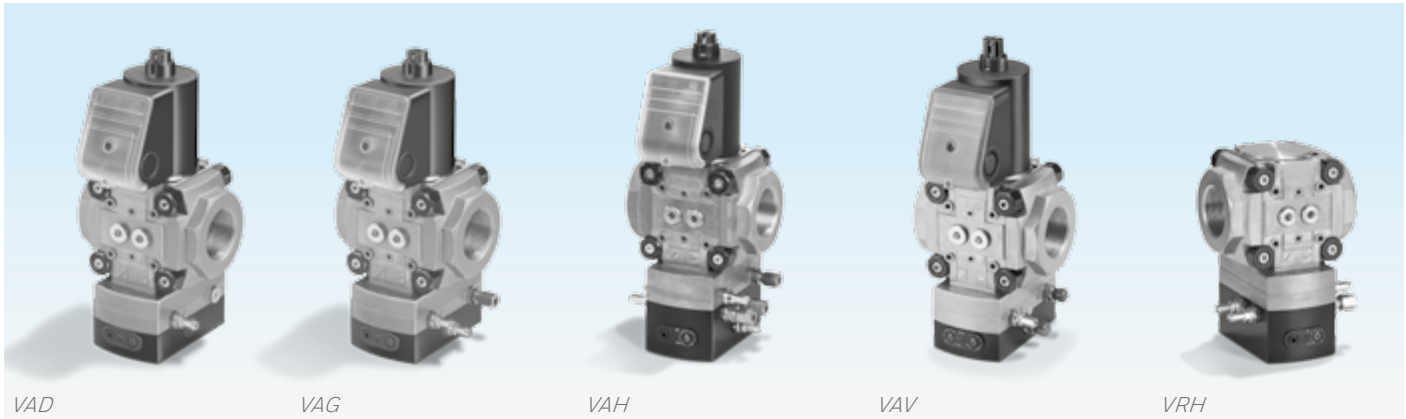

Regulators with solenoid valves are designed for shut-off, and thanks to the servo technology, for precise control of the gas supply to gas burners and gas appliances. They are used in gas control and safety systems in all sectors of the iron, steel, glass and ceramics industries, as well as in residential or commercial heat generation, such as the packaging, paper and foodstuffs industries.

VAD

Constant pressure governor, Class A, with high control accuracy, for excess air burners, atmospheric burners or single-stage forced draught burners. Pressure preset via setpoint spring. In the case of fluctuating furnace or kiln pressures, the furnace chamber pressure may also be connected for maintaining a constant burner capacity.

VAG

Air/gas ratio control, Class A, for maintaining a constant air/gas pressure ratio for modulating-controlled burners or with VAS 1 bypass valve for stage-controlled burners. Pressure preset by the air control line.

The VAG..N can also be used as a zero governor for gas engines.

VAH, VRH

Flow rate regulators VAH and VRH are used to maintain a constant gas/air ratio for modulating-controlled and stage-controlled burners. The gas flow rate is controlled proportionally to the air flow rate.

In addition, flow rate regulator VAH is designed as a gas solenoid valve and shuts off the gas or air supply safely.

VAV

Variable air/gas ratio control, Class A, for maintaining a constant gas/air pressure ratio for modulating-controlled burners. Pressure preset by the air control line. The ratio of gas pressure to air pressure remains constant. It can be set from 0.6:1 to 3:1. Pressure fluctuations in the combustion chamber can be compensated via the combustion chamber control pressure.



Pressure regulator on excess air burners in the ceramics industry



Air/gas ratio control on melting furnace for ensuring stoichiometric combustion over the entire capacity range



Aluminium age-hardening furnace with air/gas ratio controls for air deficiency cut-out

Examples of application

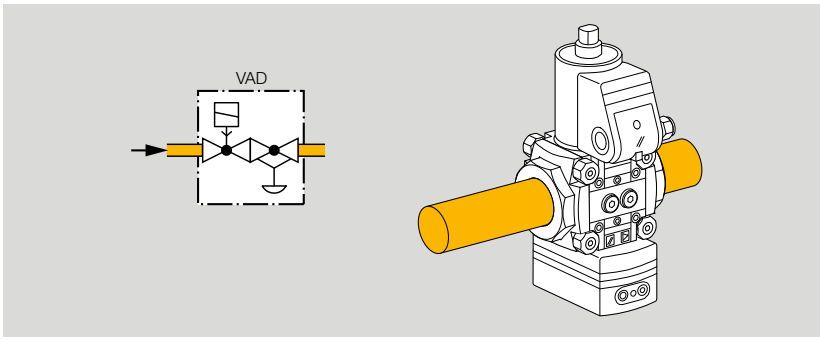

Constant pressure control

The pressure regulator with gas solenoid valve VAD maintains the set gas outlet pressure p_d constant when subject to differing flow rates. If a second gas solenoid valve is used upstream of the VAD, this complies with the requirements of EN 746-2 for two Class A gas solenoid valves connected in series.

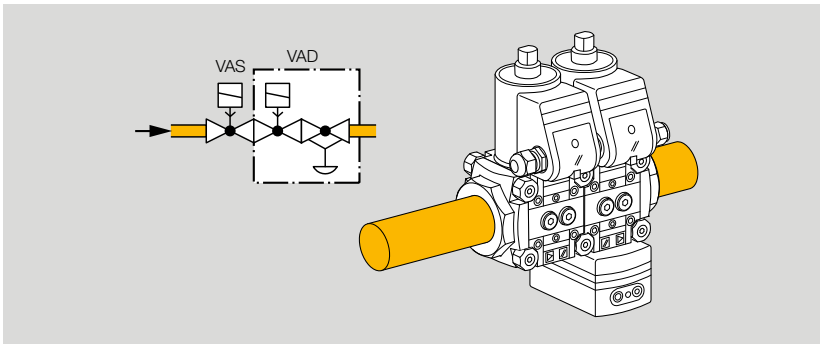

Constant pressure control with two gas solenoid valves

The pressure regulator with gas solenoid valve VAD maintains the set gas outlet pressure p_d constant when subject to differing flow rates.

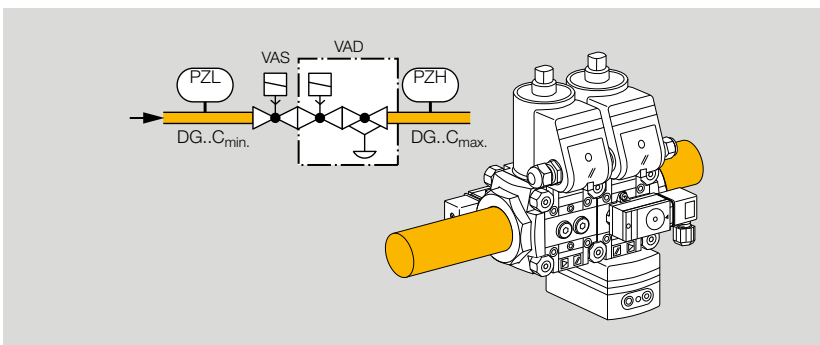

Constant pressure control with max. pressure switch

In this example, the minimum inlet pressure p_u and the maximum outlet pressure p_d are monitored with the pressure switches DG..C. The simple attachment of the pressure switch module makes installation easier.

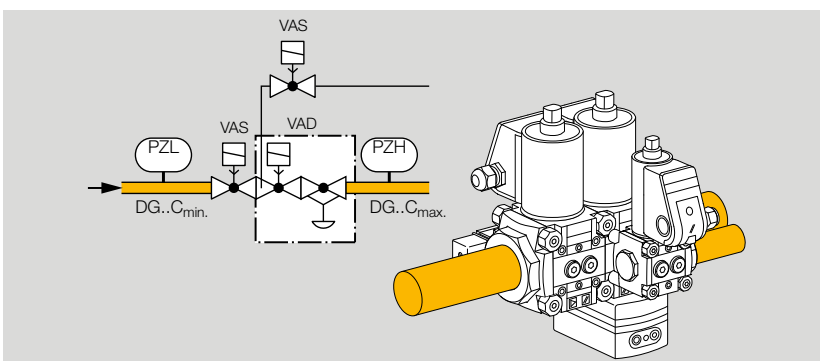

Constant pressure control with non-controlled pilot gas outlet

In this application, the pilot burner is supplied with a high inlet pressure via the pilot gas outlet. The simple attachment of the bypass valve module makes installation easier. The minimum inlet pressure p_u and the maximum outlet pressure p_d are monitored with the pressure switches DG..C.

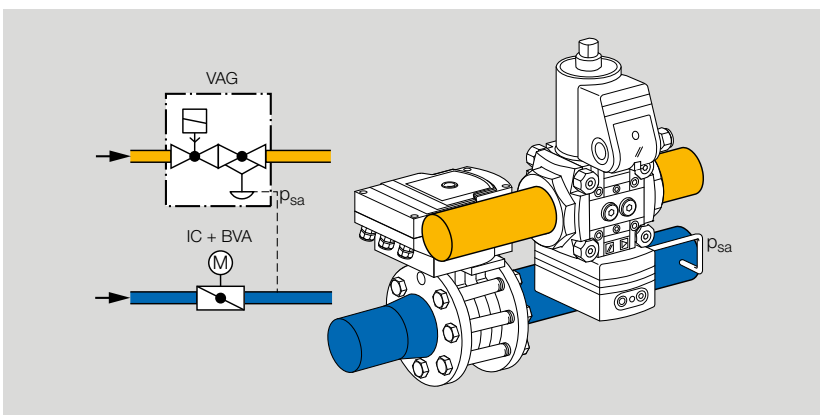

Modulating control

The gas outlet pressure p_d is controlled via the air/gas ratio control with gas solenoid valve VAG. The gas outlet pressure p_d follows the changing air control pressure p_{sa} . The ratio of gas pressure to air pressure remains constant. The VAG is suitable for a control range up to 10:1.

If a second solenoid valve is used upstream of the VAG, this complies with the requirements of EN 746-2 for two Class A valves connected in series.

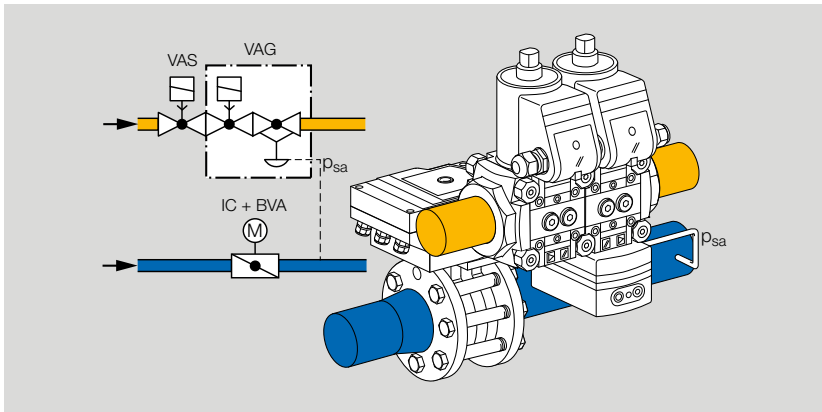

Modulating control with two gas solenoid valves

The gas outlet pressure p_d is controlled via the air/gas ratio control with gas solenoid valve VAG. The gas outlet pressure p_d follows the changing air control pressure p_{sa} . The ratio of gas pressure to air pressure remains constant. The VAG is suitable for a control range up to 10:1.

The gas line is two Class A shut-off valves connected in series, in accordance with the requirements of EN 746-2.

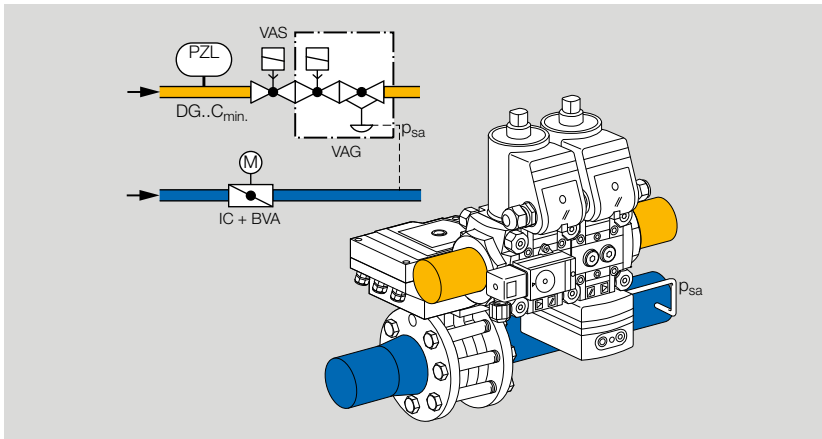

Modulating control with two gas solenoid valves and inlet pressure switch

In this case, the minimum inlet pressure p_u is monitored by the pressure switch DG..C. The simple attachment of the pressure switch module makes installation easier.

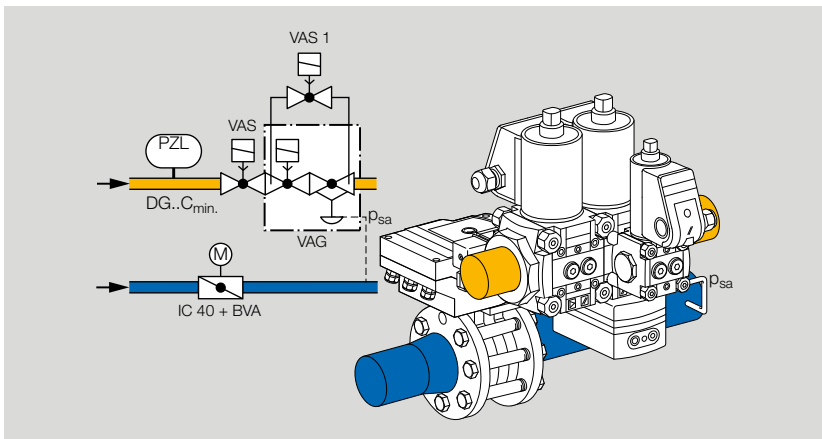

High/Low control

At high fire, the gas outlet pressure p_d follows the air control pressure p_{sa} . The ratio of gas pressure to air pressure remains constant. Low fire is determined via the bypass valve VAS 1. Here as well, the simple attachment of the bypass valve module makes installation easier.

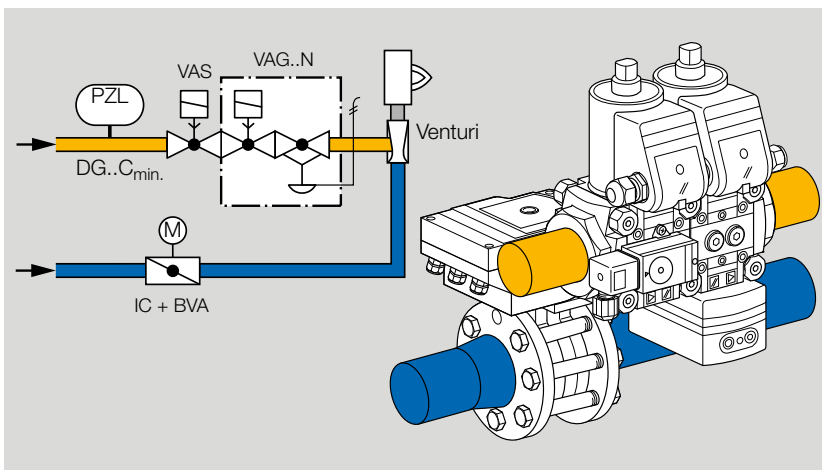

Zero pressure control

In this application, the control air pressure is the atmospheric air pressure. The air flow rate generates a negative pressure in the gas pipe via the Venturi. This negative pressure is compensated by the air/gas ratio control with gas solenoid valve VAG..N. The greater the negative pressure, the greater the gas flow rate.

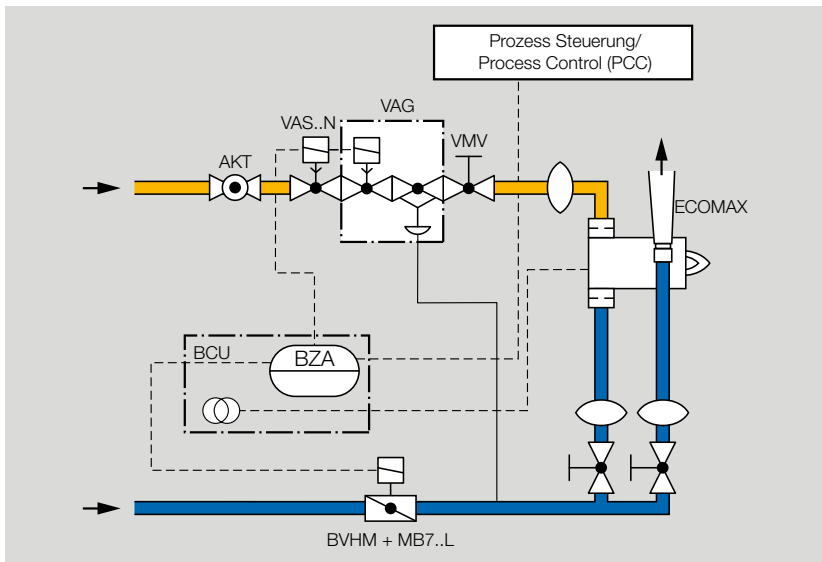

Staged flow rate control

This application shows the VAH on a self recuperative burner.

The pressure loss in the recuperator depends on the furnace or kiln temperature. When the furnace or kiln temperature is increased (at a constant air supply pressure), the flow rate drops. This change in the air flow rate is measured by the orifice and the VAH changes the gas volume accordingly.

The air index (lambda) can be set using the fine-adjusting valve VMV.

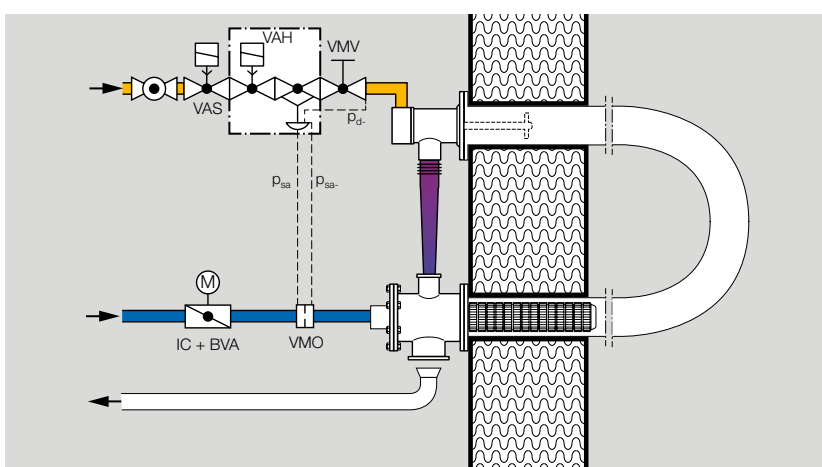

Continuous or staged flow rate control

This application shows flow rate control for a radiant tube burner system with plug-in recuperator for air preheating.

There are temperature-dependent air pressure losses in the recuperator. The ratio of gas pressure to air pressure does not remain constant. The fluctuating air flow rate is measured at the measuring orifice VMO and the VAH controls the gas flow rate proportionally.

The air index (lambda) can be set using the fine-adjusting valve VMV.

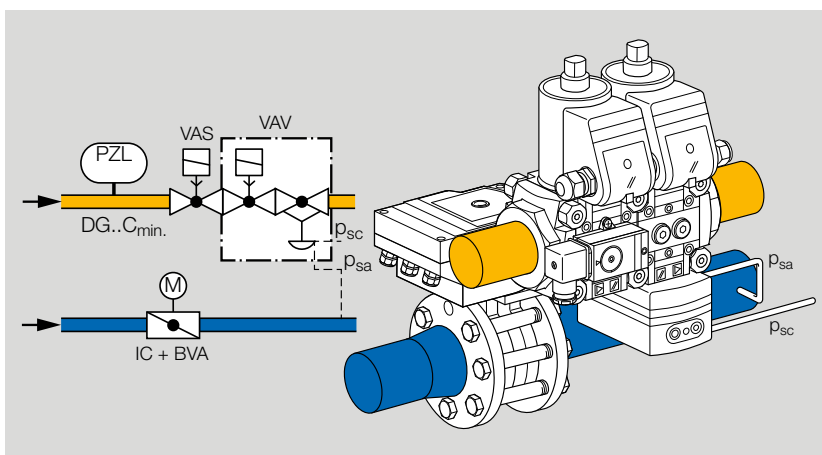

Modulating control with variable air/gas ratio control with gas solenoid valve

The ratio of gas pressure to air pressure can be adjusted infinitely between 0.6:1 and 3:1. Pressure fluctuations in the combustion chamber can be compensated via the combustion chamber control pressure p_{sc} .

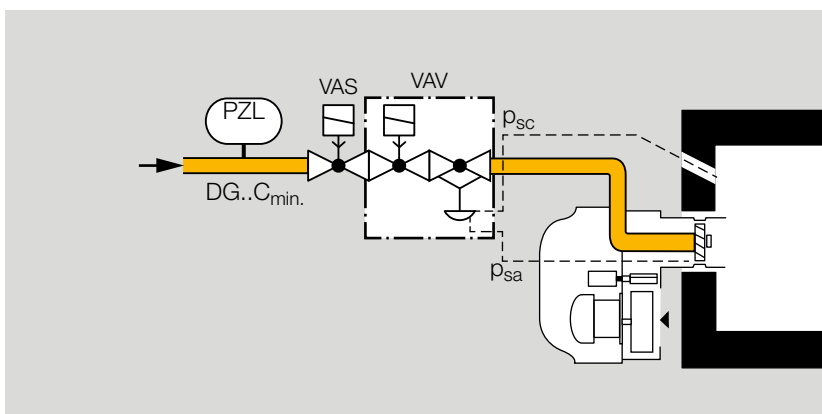

Modulating control in residential heat generation

This application shows the variable air/gas ratio control with solenoid valve VAV fitted to a modulating-controlled forced draught burner.

The combustion air volume is set via a butterfly valve for air or by adjusting the fan speed.

Type code

VAD

| Code | Description |
|----------------------|---|
| VAD | Pressure regulator with solenoid valve |
| 1 - 3 | Size |
| T | T-product |
| 15 - 65 /15 - /50 | Nominal inlet diameter Nominal outlet diameter |
| R | Rp internal thread |
| N | NPT internal thread |
| F | ISO flange |
| /N | Quick opening, quick closing |
| K | Mains voltage 24 V DC |
| P | Mains voltage: 100 V AC; 50/60 Hz |
| Q | Mains voltage: 120 V AC; 50/60 Hz |
| Y | Mains voltage: 200 V AC; 50/60 Hz |
| W | Mains voltage: 230 V AC; 50/60 Hz |
| S | CPS with visual position indicator |
| G | CPS for 24 V with visual position indicator |
| R | Viewed from the right (in the direction of flow) |
| L | Viewed from the left (in the direction of flow) |
| -25 -50 -100 | Outlet pressure p_{d} : 2.5 - 25 mbar 20 - 50 mbar 35 - 100 mbar |
| A | Standard valve seat |
| B | Reduced valve seat |

VAG, VAH, VRH

| Code | Description |
|----------------------|---|
| VAG | Air/gas ratio control with solenoid valve |
| VAH | Flow rate regulator with solenoid valve |
| VRH | Flow rate regulator |
| 1 - 3 | Size |
| T | T-product |
| 15 - 65 /15 - /50 | Nominal inlet diameter Nominal outlet diameter |
| R | Rp internal thread |
| N | NPT internal thread |
| F | ISO flange |
| /N ¹⁾ | Quick opening, quick closing |
| K ¹⁾ | Mains voltage 24 V DC |
| P ¹⁾ | Mains voltage: 100 V AC; 50/60 Hz |
| Q ¹⁾ | Mains voltage: 120 V AC; 50/60 Hz |
| Y ¹⁾ | Mains voltage: 200 V AC; 50/60 Hz |
| W ¹⁾ | Mains voltage: 230 V AC; 50/60 Hz |
| S ¹⁾ | CPS with visual position indicator |
| G ¹⁾ | CPS for 24 V with visual position indicator |
| R | Viewed from the right (in the direction of flow) |
| L | Viewed from the left (in the direction of flow) |
| A | Standard valve seat |
| B | Reduced valve seat |
| E K A N | Connection kit for air control pressure p_{sa} : VAG, VAH, VRH: compression fitting VAG: plastic hose coupling VAG, VAH, VRH: NPT 1/8 adapter VAG: zero governor |

¹⁾ Only available for VAG, VAV, VAH.

VAV

| Code | Description |
|----------------------|---|
| VAV | Variable air/gas ratio control with solenoid valve |
| 1 - 3 | Size |
| T | T-product |
| 15 - 65 /15 - /50 | Nominal inlet diameter Nominal outlet diameter |
| R | Rp internal thread |
| N | NPT internal thread |
| F | ISO flange |
| /N | Quick opening, quick closing |
| K | Mains voltage 24 V DC |
| P | Mains voltage: 100 V AC; 50/60 Hz |
| Q | Mains voltage: 120 V AC; 50/60 Hz |
| Y | Mains voltage: 200 V AC; 50/60 Hz |
| W | Mains voltage: 230 V AC; 50/60 Hz |
| S | CPS with visual position indicator |
| G | CPS for 24 V with visual position indicator |
| R | Viewed from the right (in the direction of flow) |
| L | Viewed from the left (in the direction of flow) |
| A | Standard valve seat |
| B | Reduced valve seat |
| E K A | Connection kit for air control pressure p_{sa} and combustion chamber control pressure p_{sc} : compression fitting plastic hose coupling NPT 1/8 adapter |

Replacement possibilities for MODULINE pressure regulators with gas solenoid valve

GVS, GVI, GVIB, GVR and GVRH are to be replaced by VAD, VAG, VAG+VAS, VAH and VAV

Technical data

Gas types: natural gas, LPG (gaseous), biogas (max. 0.1 %-by-vol. H₂S) or clean air; other gases on request. The gas must be clean and dry in all temperature conditions and must not contain condensate.

CE and FM approved, UL listed, max. inlet pressure p_{in} :

10 – 500 mbar (4 – 200 "WC),

FM approved (230 V AC, 120 V AC, 24 V DC), non operational pressure: 700 mbar (10 psig).

ANSI/CSA approved (230 V AC, 120 V AC, 24 V DC) up to 350 mbar (5 psig).

Opening time of the solenoid valve:

quick opening: ≤ 0.5 s,

Closing time: quick closing: < 1 s.

Medium and ambient temperatures:

-20 to +60°C (-4 to +140°F), no condensation permitted.

Long-term use in the upper ambient temperature range accelerates the ageing of the elastomer materials and reduces the service life (please contact manufacturer).

Storage temperature:

-20 to +40°C (-4 to +104°F).

Enclosure: IP 65.

Valve housing: aluminium, valve seal: NBR.

Connection flanges with internal thread:

Rp to ISO 7-1, NPT to ANSI/ASME.

Safety valve: Class A to EN 161,

Factory Mutual Research Class: 7400 Process Control Valves (230 V AC, 120 V AC, 24 V DC),

ANSI Z21.21 and CSA 6.5,

ANSI Z21.18 and CSA 6.3.

Control class A to EN 88-1.

Control range: up to 10:1.

Mains voltage:

230 V AC, +10/-15%, 50/60 Hz;

200 V AC, +10/-15%, 50/60 Hz;

120 V AC, +10/-15%, 50/60 Hz;

100 V AC, +10/-15%, 50/60 Hz;

24 V DC, $\pm 20\%$.

Duty cycle: 100%.

Power factor of the solenoid coil: $\cos \varphi = 0,9$.

Power consumption:

| Type | Voltage | Power | |
|--------------|----------|-------|---------|
| VAX 1 | 24 V DC | 25 W | - |
| | 100 V AC | 25 W | (26 VA) |
| | 120 V AC | 25 W | (26 VA) |
| | 200 V AC | 25 W | (26 VA) |
| | 230 V AC | 25 W | (26 VA) |
| VAX 2, VAX 3 | 24 V DC | 36 W | - |
| | 100 V AC | 36 W | (40 VA) |
| | 120 V AC | 40 W | (44 VA) |
| | 200 V AC | 40 W | (44 VA) |
| | 230 V AC | 40 W | (44 VA) |
| VBY | 24 V DC | 8 W | - |
| | 120 V AC | 8 W | - |
| | 230 V AC | 9,5 W | - |

Cable gland: M20 × 1.5.

Electrical connection: cable with max. 2.5 mm² (AWG 12) or plug with socket to EN 175301-803.

Closed position switch contact rating:

| Type | Voltage | Min. current (resistive load) | Max. current (resistive load) |
|----------------|-------------------------|-------------------------------|-------------------------------|
| VAX..S, VCx..S | 12 – 250 V AC, 50/60 Hz | 100 mA | 3 A |
| VAX..G, VCx..G | 12 – 30 V DC | 2 mA | 0.1 A |

Closed position switch switching frequency:

max. 5 × per minute.

| Switching current [A] | Switching cycles* | |
|-----------------------|--------------------|----------------------|
| | $\cos \varphi = 1$ | $\cos \varphi = 0.6$ |
| 0.1 | 500,000 | 500,000 |
| 0.5 | 300,000 | 250,000 |
| 1 | 200,000 | 100,000 |
| 3 | 100,000 | - |

* Limited to max. 200,000 cycles for heating systems

VAD

Outlet pressure p_d :

VAD..-25: 2.5 – 25 mbar (1 – 10 "WC),

VAD..-50: 20 – 50 mbar (8 – 20 "WC),

VAD..-100: 35 – 100 mbar (14 – 40 "WC).

Combustion chamber control pressure p_{sc} (connection p_{sa}): -20 to +20 mbar (-7.8 to +7.8 "WC).

VAG

Outlet pressure p_d : 0.5 – 100 mbar (0.2 – 40 "WC).

Air control pressure p_{sa} : 0.5 – 100 mbar (0.2 – 40 "WC).

Adjusting range at low fire: ± 5 mbar (± 2 "WC).

Transmission ratio of air to gas: 1:1.

VAH, VRH

Air control pressure p_{sa} :

0.6 – 100 mbar (0.24 – 40 "WC).

Differential air pressure Δp_{sa} ($p_{sa} - p_{sa-}$):

0.6 – 50 mbar (0.24 – 19.7 "WC).

Differential gas pressure Δp_d ($p_d - p_{d-}$):

0.6 – 50 mbar (0.24 – 19.7 "WC).

Transmission ratio of gas to air: 1:1.

Adjusting range at low fire: ± 5 mbar (± 2 "WC).

VAV

Outlet pressure p_d :

0.5 – 30 mbar (0.2 – 11.7 "WC).

Air control pressure p_{sa} :

0.4 – 30 mbar (0.15 – 11.7 "WC).

Combustion chamber control pressure p_{sc} :

-20 to +20 mbar (-7.8 to +7.8 "WC).

Min. control pressure differential $p_{sa} - p_{sc}$:

0.4 mbar (0.15 "WC).

Min. pressure differential $p_d - p_{sc}$:

0.5 mbar (0.2 "WC).

Adjusting range at low fire: ± 1.5 mbar (± 0.6 "WC).

Transmission ratio of air to gas: 0.6:1 to 3:1.

Maintenance cycles

At least once per annum, at least twice per annum for biogas.

If the flow rate drops, clean the strainer.

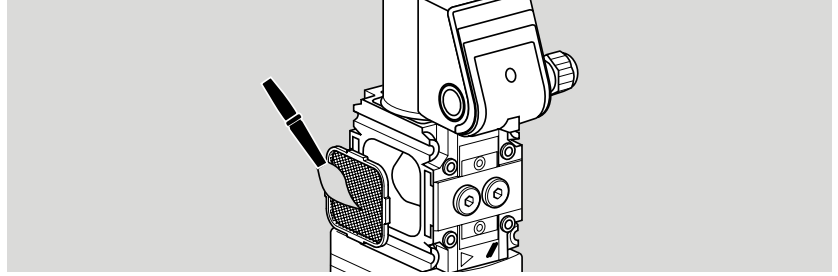

Flow rate

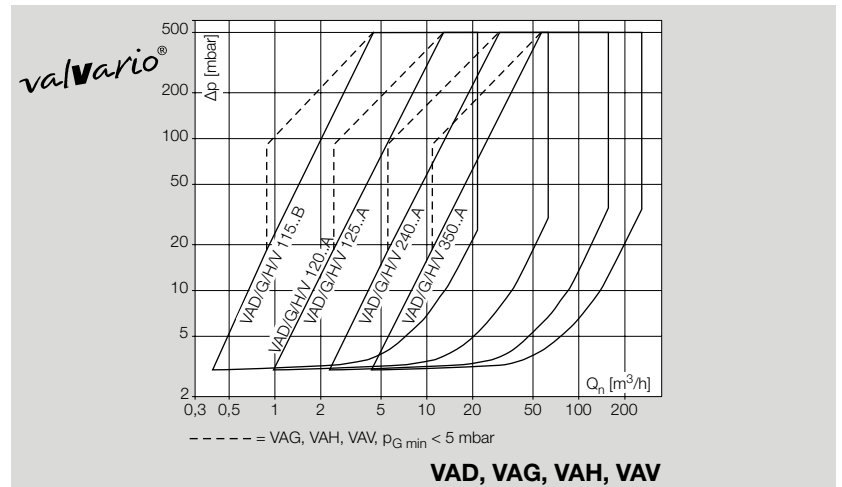

Ordering Information: Part No. KR153245

T: 1800 225 572 | F: 1800 289 723 | E: sales@systemcontrol.com.au | W: systemcontrol.com.au

In support of our policy of continuous product improvement we reserve the right to change materials and specifications without notice. Drawings, where used, are not to scale. All dimensions are in millimetres and sizes given are approximate. Where possible, technical MSDS data sheets are made available on the website. All products should be installed and used in accordance with manufacturer's instructions provided. Warning: products may be the subject of registered designs and patents. Refer to website for terms and conditions on warranty.

SCE
SYSTEM CONTROL
ENGINEERING